

A review on fundamental grid-voltage detection methods under highly distorted conditions in distributed power-generation networks

A.Naveen kumar¹, K.Vijayabhaskar², B.Devendar³

¹ (ELECTRICAL AND ELECTRONICS ENGINEERING, SVP CET, INDIA)

² (ELECTRICAL AND ELECTRONICS ENGINEERING, SVP CET, INDIA)

³ (ELECTRICAL AND ELECTRONICS ENGINEERING, SVP CET, INDIA)

ABSTRACT : The stability of fixed-speed induction generator (FSIG)-based wind turbines can be improved by a StatCom, which is well known and documented in the literature for balanced grid voltage dips. Under unbalanced grid voltage dips, the negative-sequence voltage causes heavy generator torque oscillations that reduce the lifetime of the drive train. In this paper, investigations on an FSIG-based wind farm in combination with a StatCom under unbalanced grid voltage fault are carried out by means of theory, simulations, and measurements. A StatCom control structure with the capability to coordinate the control between the positive and the negative sequence of the grid voltage is proposed. The results clarify the effect of the positive- and the negative-sequence voltage compensation by a StatCom on the operation of the FSIG-based wind farm. With first priority, the StatCom ensures the maximum fault-ride-through enhancement of the wind farm by compensating the positive-sequence voltage. The remaining StatCom current capability of the StatCom is controlled to compensate the negative-sequence voltage, in order to reduce the torque oscillations. The theoretical analyses are verified by simulations and measurement results on a 22-kW laboratory setup.

KEYWORDS: Induction generator, low-voltage ride through, StatCom, wind energy.

I. INTRODUCTION

WIND energy is playing a key role on the way toward a sustainable energy future. Among the generator types used for wind turbines, the technical development has moved from fixed-speed to variable-speed concepts [1]. Although a major part of the newly installed wind turbines are of the variable-speed type using either a doubly fed induction generator (DFIG) or permanent-magnet synchronous generator, a non negligible percentage of 15% of the operating wind turbines in Europe in 2010 [2] is still of the fixed-speed induction generator (FSIG)-type directly connected to the grid. Because this generator type cannot provide reactive power control, it cannot fulfill the demanding grid code requirements [3] without additional devices. During voltage dips, the induction generators may consume a large amount of reactive power as their speed deviates from the synchronous speed, which can lead to a voltage collapse and further fault propagation in the network.

Different methods have been investigated to enhance the fault-ride-through capability and to fulfill grid code requirements. Besides using the pitch control of the turbine or installing additional equipment like a brake chopper or an energy storage system, the installation of a StatCom has been identified to provide the best dynamic stability enhancement capabilities [4]. A StatCom is a voltage source converter-based device providing dynamic reactive power support to the grid. Multilevel, [5] or hexagram converter topologies are usually chosen to implement the high-power converters. Due to its flexible dynamic control capabilities, the StatCom can help to integrate wind power plants in a weak power system [6]. The capability of a static var compensator compared to a StatCom to increase the stability of FSIG-based wind turbines is given in [7] and [8]. The StatCom can also perform an indirect torque control for the same kind of generators [7], [8] to decrease the mechanical stress during grid voltage dip. All these investigations have covered balanced grid faults, but the majority of grid faults are of the unbalanced nature. The unbalanced-voltage problem can cause unbalanced heating in the machine windings and a pulsating torque, leading to mechanical vibration and additional acoustic noise. The StatCom control structure can be adapted to these unbalanced-voltage conditions, and the positive and the negative sequence of the voltage can be controlled independently. Different current injection methods based on symmetrical components can also be applied to the StatCom, resulting in different output-power distributions. How these different current injection targets affect the operation of an FSIG-based wind farm is investigated in [9] and [10]. However, regarding the damping of the torque ripple of the generators, it is more effective to control the positive- and the negative-sequence voltage. A voltage balancing control of a StatCom connected to induction motors is presented in [11] and [12]. The negative-sequence voltage control can also be performed by a DFIG wind farm in the vicinity of the FSIG-based wind farm. So far, however, no studies have been found on the coordination between the positive- and the negative-sequence voltage control of a StatCom at an FSIG-based wind farm.

This paper proposes the application of a StatCom that is connected to an FSIG-based wind farm and used to control the positive- and the negative-sequence voltage during grid faults. The novel contribution of this paper lies in the coordination of the positive- and the negative-sequence voltage control by the StatCom and the related effect on the wind turbine behavior. While the positive-sequence voltage compensation leads to an increased voltage stability of the wind farm, the negative-sequence voltage compensation leads to a reduction of torque ripple, increasing the lifetime of the generator drive train. First investigations have been published in , but here, deeper analysis and measurement results are presented.

II. HEADING S

- I. POWER SYSTEM STRUCTURE
- II. INDUCTION GENERATOR UNDER VOLTAGE DIP
- III. STATCOM CONTROL STRUCTURE
- IV. RESULTS FOR UNBALANCED GRID FAULTS

III. INDENTATIONS AND EQUATIONS

II. POWER SYSTEM STRUCTURE

The investigated power system is shown in Fig. 1 and consists of a 50-MW wind farm with squirrel cage induction generators directly connected to the grid and a 50-MVA StatCom.

An aggregate model of the wind farm is used as usual here, which means that the sum of the turbines is modeled as one generator using the standard T-equivalent circuit. The StatCom is modeled as controlled voltage sources. Both devices are connected to the same low voltage bus and then connected to the medium voltage bus by a transformer. The medium voltage level is connected to the high voltage level by a second transformer. Both transformers are rated for the sum of the wind farm and StatCom power and have a series impedance of 5% and 10% per unit. The grid fault is assumed at the high voltage level of the grid, which is modeled by its Thevenin equivalent. All power system parameters are given in Tables I and II. The power system is modeled with the power electronics and electric circuit toolbox PLECS, while the control structure is modeled in Simulink.

III. INDUCTION GENERATOR UNDER VOLTAGE DIP

The torque of the induction generator T^+ shows a quadratic dependence of the positive-sequence stator voltage magnitude V_{s^+} . It can be calculated using

$$T^+(s) = 3 \cdot \frac{p}{2} \cdot \frac{R_r}{s\omega_s} \cdot \frac{(V_{s^+})^2}{(R_s + R_r/s)^2 + j(X_s + X_r)^2} \quad (1)$$

where R_s , R_r , X_s , and X_r are the typical stator and rotor (subscripts s and r) resistance and impedance parameters of the machine equivalent circuit, p is the number of pole pairs, ω_s is the grid frequency, and s is the slip. When the theoretical steady-state torque–slip characteristic of the induction machine is plotted based on the steady-state equivalent circuit of the machine for different stator voltages as shown in Fig. 2, the instability during balanced grid voltage dips becomes clear. Transient torque peaks caused by the dynamic change of the grid voltage as identified in are not addressed here. Usually, the wind turbine operates at nominal stator voltage in operation point A where the electromechanical torque is the same as the mechanical torque. When the stator voltage is reduced due to a grid fault, the torque–slip characteristic changes. If the voltage dip is smaller, the induction generator may resume a stable operation point C via B. However, for a deep voltage dip, the induction generator will deviate from point D to an unstable operation. The induction generators may have to be disconnected from the grid due to over speed, or there may be a voltage collapse in the network due to the high consumption of reactive power at higher slip. When the grid voltage is unbalanced, i.e., it contains a negative sequence, the stator currents become unbalanced too. According to Wang et al. [24], a small amount of negative-sequence voltage V_{s^-} can lead to a high amount of negative-sequence currents I_{s^-} , described by

$$I_{s^-,pu}^- = \frac{V_{s^-}}{\omega_s \cdot \sigma \cdot L_s \cdot I_{s,N}} \quad (2)$$

where σ is the leakage factor, $I_{s,N}$ is the rated stator current, and L_s is the stator inductance. The negative-sequence currents do not contribute a lot to the average torque T^+ ; thus, they can still be calculated using

$$T^+ \approx 3 \cdot \frac{p}{2\omega_s} \cdot V_{s^+} \cdot I_{sd}^+ \quad (3)$$

but the negative-sequence currents cause torque oscillations of double grid frequency. The magnitude of the negative-sequence torque T^- can be calculated using

$$T^- \approx 3 \cdot \frac{P}{2\omega_s} \cdot V_s^+ \cdot I_s^- \quad (4)$$

It becomes clear that the average torque is reduced due to the decreased positive-sequence voltage. Additionally, there are high torque oscillations of double grid frequency due to the negative-sequence voltage. Thus, a reduction of the positive-sequence stator voltage will lead to a reduction of the average torque and an acceleration of the turbine. An existing negative-sequence stator voltage will cause torque oscillations, reducing the lifetime of the turbine drive train. When the positive- and the negative-sequence voltage can be controlled independently by a StatCom, the average torque and the torque ripple can also be controlled independently. The proposed StatCom control structure is presented in the next section.

IV. STATCOM CONTROL STRUCTURE

The StatCom control structure is based on the voltage-oriented vector control scheme as usually applied to three-phase grid-connected converters. It is a cascade control structure with inner proportional (PI) current controllers in a rotating dq reference frame with grid voltage orientation. The PI controller transfer function is

$$G_{PI}(s) = V_R \frac{1 + s \cdot T_n}{s \cdot T_n} \quad (5)$$

The modeling and controller gain design of voltage-oriented controlled three-phase grid-connected converters are described in. Resonant controllers (Res) tuned at 100 Hz in the same positive dq reference frame are added to realize the negative-sequence current control.

$$G_{Res}(s) = K_{res} \cdot \frac{s}{s^2 + (2 \cdot \omega_0)^2} \quad (6)$$

Note that the control of the negative-sequence currents can also be performed in a negative rotating reference frame with PI controllers, but by using resonant controllers in a positive rotating reference frame, there is no need for a sequence separation of the currents. The overall control structure is shown in Fig. 3. Note that a possible StatCom converter topology is shown here as a two-level voltage source converter connected to the grid by an *LCL* filter, while multilevel topologies will be used for high power applications. The outer control loop are designed to control the DC voltage and the positive and negative sequences of the voltages at the connections points of the statcom. Therefore, a precise sequence separation of the measured voltage into positive- and negative-sequence components is necessary, which is performed based on dual second-order generalized integrators [9]. Other sequence extraction methods could be applied. Using the sequence separation, the positive and the negative sequence of the voltage appear as dc values and can be controlled by PI controllers. To ensure a safe operation of the StatCom within its current capability, the current references given by the four outer controllers must be limited to the maximum StatCom current.

The priority is on the positive-sequence reactive current I_q^+ . Thus, the StatCom ensures the maximum fault-ride-through enhancement of the wind farm by compensating the positive-sequence voltage. If there is a remaining StatCom current capability, the StatCom is controlled to compensate the negative-sequence voltage additionally, in order to reduce the torque ripple during the grid fault.

The positive- and negative-sequence current references are added. The negative-sequence current references must be transformed into the positive rotating reference frame by a coordinate transformation with twice the grid voltage angle. Note that the transient torques at the beginning and end of the grid fault remain uncompensated using this control strategy. A control strategy to smooth the torque transients is not focus of this paper and is investigated in [11]. For the investigations under unbalanced grid fault, different control targets will be compared to clarify the effect of the positive- or the negative-sequence voltage compensation on the operation of the induction generators. The target of the first method is to compensate the positive-sequence voltage, while the negative-sequence voltage will remain unchanged. The target of the second method is to eliminate the negative sequence of the voltage, while the positive sequence voltage will remain unchanged. Both methods are shown in the next section. In Section VI, simulation results for a coordinated positive- and negative-sequence voltage control are shown 3.

V. RESULTS FOR UNBALANCED GRID FAULTS

In this section, simulation results for the operation of the induction generators and the stabilization by the StatCom under an unbalanced grid voltage dip of 500-ms duration are presented and discussed. An unbalanced fault (single phase amplitude drops to 50%) is assumed at the high voltage bus of the power system see Fig. 1. The simulation results are shown in Figure below. The un-balanced grid fault leads to a negative-sequence voltage at the medium voltage bus. The operation of the system without StatCom support is shown in the Fig. 4. The phase voltage at without statcom figure 5. The reduction of the positive-sequence voltage leads to a decrease in torque and an acceleration of the rotor. The important difference compared to a balanced grid fault are the heavy torque oscillations of the system caused by the negative-sequence voltage. For this simulation case, the grid voltage fault does not lead to a voltage instability because the generator can return to the rated operation point after the fault, but there is very high stress on the mechanical parts of the system due to the torque oscillations. Simulink output of the wind farm at without statcom figure show in figure 6. the simulation results are shown for the same grid fault, but now, the system is supported by the StatCom. In this case, the StatCom is controlled to compensate the positive sequence of the voltage. Within the Chosen current rating of the StatCom (here, 1 p.u.), the positive-sequence voltage at the low voltage level can fully be compensated by injecting a positive-sequence StatCom current see figure 7. Note that the current is purely reactive, which cannot be seen from the figure, as only the magnitude of the positive- and negative-sequence components is shown. The negative-sequence voltage component is not controlled and thus remains unaffected. The compensation of the positive-sequence voltage guarantees the full torque capability of the generator, and thus, the speed does not increase see figure 7. However, the presence of a negative-sequence voltage component leads to high torque oscillations. the StatCom is controlled to eliminate the negative-sequence component of the grid voltage. This is only possible by injecting a negative-sequence current into the grid shown in figure 9. The chosen strategy leads to a complete elimination of the negative-sequence voltage at the StatCom voltage bus, and thus, the heavy torque oscillations during the unbalanced grid faults are eliminated too. The positive-sequence voltage is not compensated here, and thus, the generator accelerates, leading to a continuous decrease in the positive-sequence voltage component see the figure 7 due to the reactive power consumption. However, the system does not reach the stability limit, and the generator returns to nominal operation after the grid fault.

Note that the drawback of the chosen StatCom control strategy in this case might be the oscillating active and reactive powers of the StatCom. In particular, the 100-Hz oscillations in the active power must be taken into account in the dimensioning of the StatCom. the torque is plotted against the speed of the induction generator taken from the same simulation results. When the StatCom is disabled, the generator accelerates, and high torque oscillations are present during the acceleration process. When the StatCom compensates the positive-sequence voltage dip, the acceleration of the generator is avoided, but the torque oscillations due to the negative-sequence voltage component are still present. When the StatCom is controlled to compensate the negative sequence voltage, the torque oscillations can be eliminated during the fault, but the generators accelerate slightly. The transient torques at the beginning and end of the grid fault remain uncompensated using this control strategy. A control strategy to smooth the torque transients is investigated in The results of this section enhance the understanding of the voltage control performed by the StatCom and the resulting operation of the induction generators. By compensating the positive-sequence voltage, the torque capability of the induction generators is increased, and an acceleration during grid voltage dips can be decreased or avoided. By compensating the negative-sequence voltage (the unbalanced component of the voltage), the torque oscillations of the induction generators can be decreased or avoided. The capability of the StatCom to compensate a voltage component depends on the chosen current rating of the StatCom and the impedance of the power system. For a high current rating of the StatCom and a weak power system (with high system impedance), the voltage compensation capability of the StatCom is also increased.

In the previous section, either the positive-sequence voltage or the negative-sequence voltage was compensated by the StatCom. For smaller voltage dips, there might be a certain amount of unused current capability of the StatCom. The current capability of the StatCom can be further exploited if positive- and negative-sequence voltage components are compensated in coordination. A prioritization of the positive sequence is proposed here in order to increase the voltage stability of the wind farm. If the StatCom has remaining current capability, it is used for the negative-sequence voltage compensation, leading to a reduction of torque ripple and increasing the lifetime of the generator drive train. Special focus is put on the maximum current capability of the StatCom that cannot be exceeded in order to avoid tripping of the converter. Simulation results for the operation during an unbalanced voltage dip (1 ph \rightarrow 60%) when both the positive- and the negative-sequence voltage components are compensated are shown in Figure 10. The current capability of the StatCom is sufficient to compensate both voltage components. For a more severe voltage dip (single phase to ground at high voltage level) as shown in Figure 11, the current capability of the StatCom is no more sufficient to compensate both voltage components. Thus, the current limitation with positive sequence priority ensures a maximum

compensation of the positive-sequence voltage. The drawback is obviously that there is no current capability left to compensate the negative-sequence voltage, and therefore, the torque oscillations are present and stress the mechanical parts of the generator.

IV. FIGURES AND TABLES

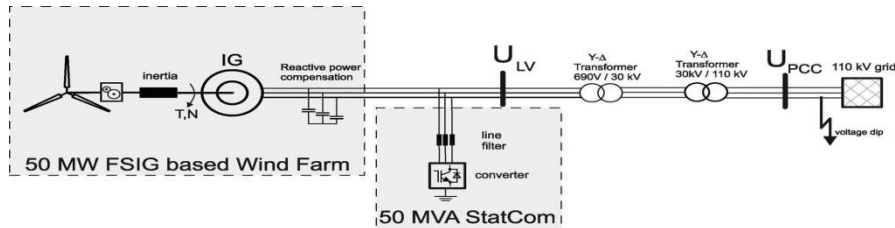

Fig. 1. Structure of the investigated system: FSIG-based wind farm and StatCom connected to the grid

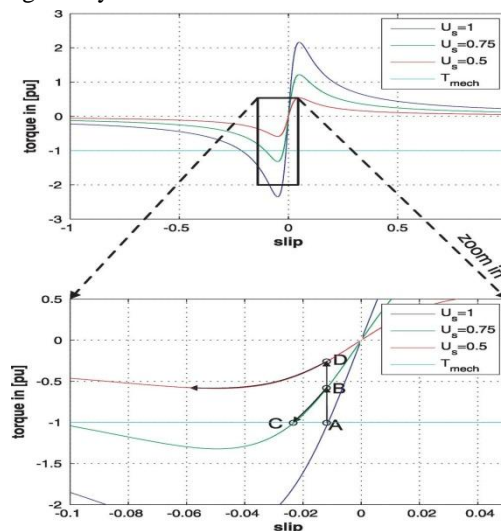

Fig. 2. Theoretical torque-slip characteristics of the induction generator under different grid voltage levels

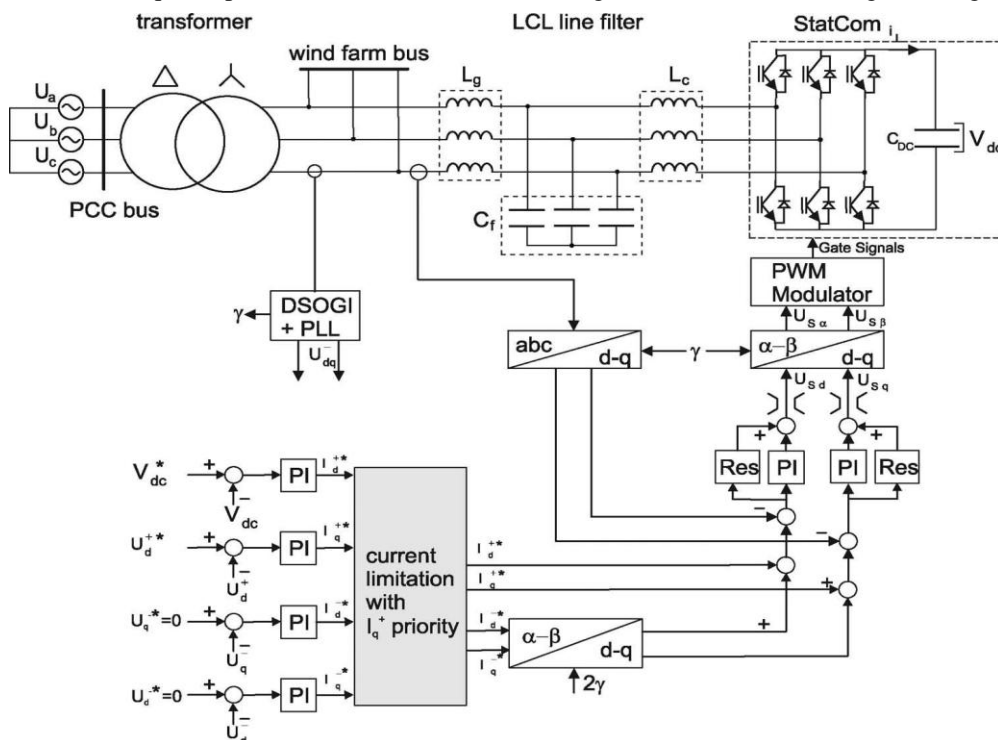

Fig. 3. Proposed control structure of the StatCom to control the positive- and the negative-sequence voltage independently

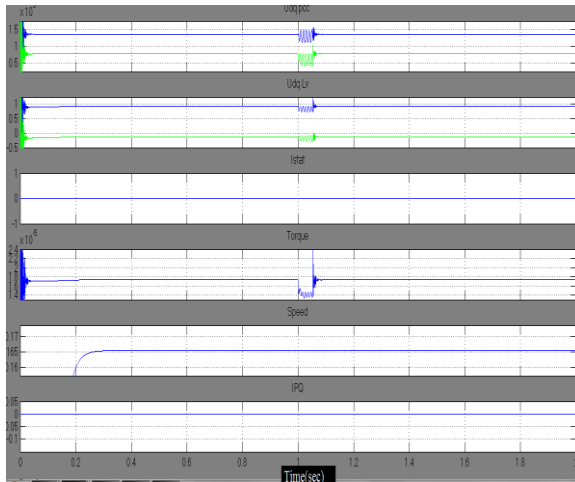

Fig.4

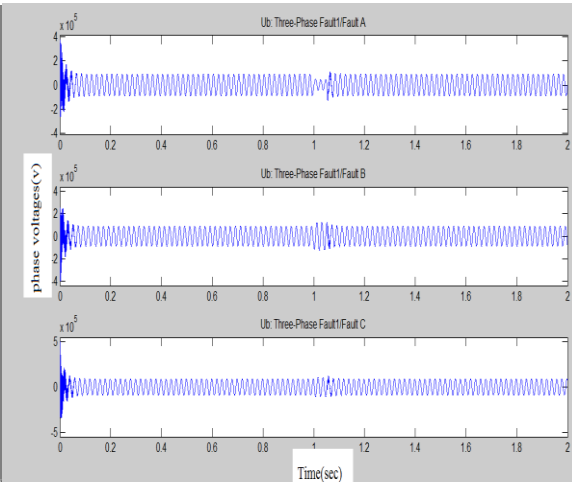

Fig.5

Fig 4. No load voltage, output voltage, torque and speed at Without StatCom 1ph-50 %

Fig 5. Phase voltages at Without StatCom 1ph-50 %

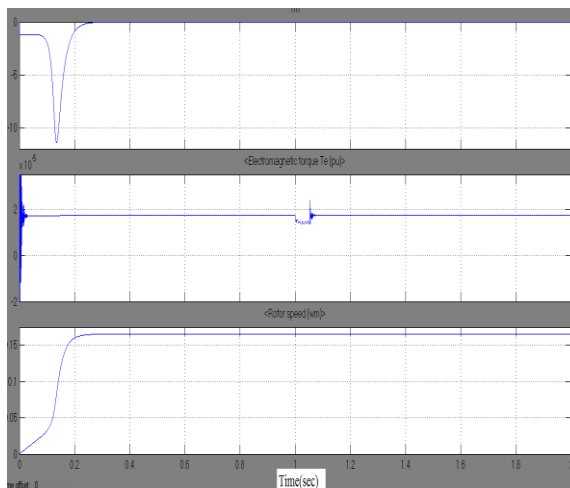

Fig 6. Simulink output of the wind farm at Without StatCom- 1ph-50 % with

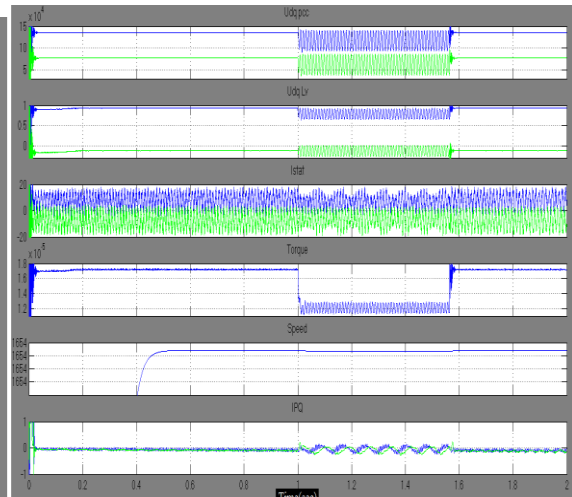

Fig 7. No load voltage, output voltage, StatCom current, torque, speed, active and reactive power at StatCom –1ph-50 % -Positive Sequence Compensation

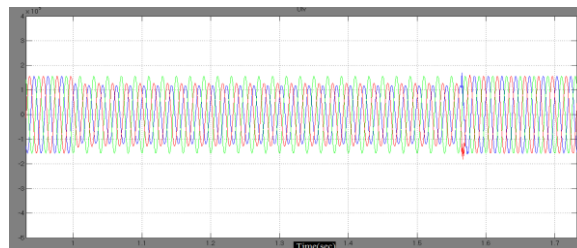

Fig 8. Source voltage at Wind Turbine fed FSIG-With StatCom

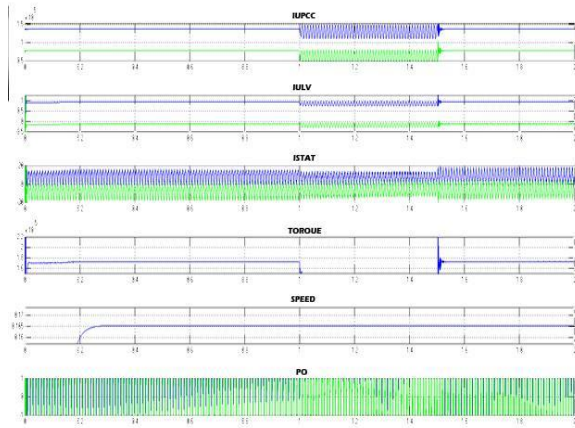

Fig 9. Output at With StatCom -1ph-50 % -Negative Sequence Compensation Sequence

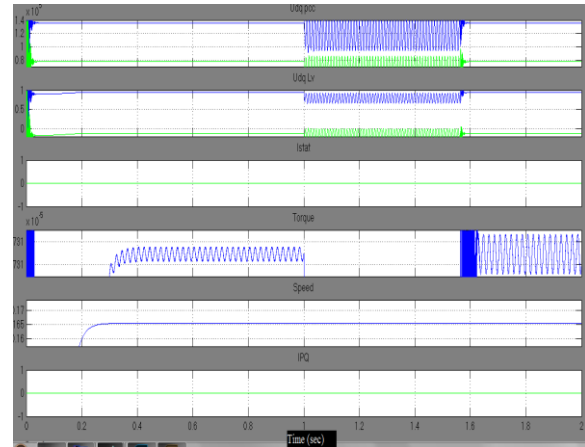

Fig 10. Output voltage, torque, speed at With statcom 1ph-60 % -Coordinated Positive -Negative Sequence Compensation

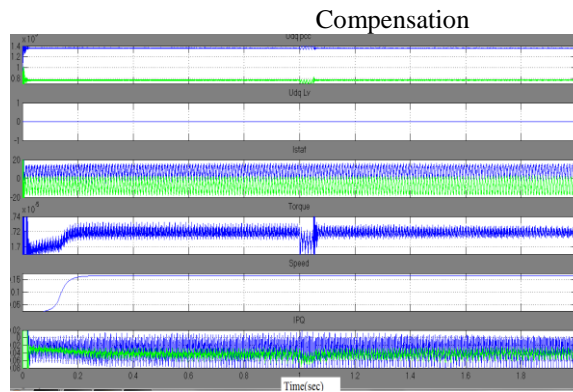

Fig 11. StatCom -1ph-0 % -Coordinated Positive -Negative Sequence Compensation

TABLE I

Wind farm induction generator and STATCOM parameter

Wind form induction generator	Simulation	lab
Base apparent power	57.5MW	-
Rated active power	50MW	22kW
Rated voltage	690V	400V
Stator resistance(R_s)	0.0108pu	0.0155pu
Stator stray impedance(X_{s0})	0.107pu	0.056pu
Mutual impedance(X_h)	4.4pu	1.61pu
Rotor resistance (R_r)	0.01214pu	0.374pu
Rotor stray impedance(X_{r0})	0.1407pu	0.0187pu
Compensation capacitor	0.17F	-
Mechanical time constant H	3s	-
Statcom		
Rated power	50Mvar	22kVA
Rated voltage	690V	400V
Line filter L_{filter}	0.15pu	2.5mH
$L_{Nfilter}$	-	2.5mH
DC voltage U_{DC}	1200V	700V
Current capability	1pu	50A

TABLE II

Grid and transformer parameters used in the simulations

	grid	HV transformer	MV transformer
Base apparent power	1000MW	100MW	100MW
rated voltage	110V	30V	690V
Stray impedance (X_g)	0.98pu	0.05pu	0.1pu
Resistance (R_g)	0.02pu	0.01pu	0.02pu

V. CONCLUSION

voltage control structure for a StatCom at an FSIG-based wind farm under unbalanced grid voltage condition has been analyzed. The proposed structure controls the positive and the negative sequence of the voltage independently with priority on the positive-sequence voltage. The novel contribution of this paper lies in the coordination of the positive- and the negative-sequence voltage control by the StatCom and the related effect on the wind turbine behavior. While the positive-sequence voltage compensation leads to an increased voltage stability of the wind farm, the negative-sequence voltage compensation leads to a reduction of torque ripple, increasing the lifetime of the generator drive train. The coordination is realized by prioritizing the positive-sequence voltage control. If there is re-remaining StatCom current capability, the StatCom is controlled to compensate the negative-sequence voltage additionally, in order to reduce the torque ripple during the grid fault.

VI REFERENCES

- [1] M. Liserre, R. Cardenas, M. Molinas, and J. Rodriguez, "Overview of multi-MW wind turbines and wind parks," *IEEE Trans. Ind. Electron.*, vol. 58, no. 4, pp. 1081–1095, Apr. 2011.
- [2] F. Van Hulle and N. Fichaux, "Powering Europe: Wind energy and the electricity grid," Eur. Wind Energy Assoc., Brussels, Belgium, Nov. 2010.
- [3] M. Tsili and S. Papathanassiou, "A review of grid code technical re-quirements for wind farms," *IET Renewable Power Gener.*, vol. 3, no. 3, pp 308–332, Sep. 2009.
- [4] M. Ali and B. Wu, "Comparison of stabilization methods for fixed speed wind generator systems," *IEEE Trans. Power Del.*, vol. 25, no. 1, pp 323–331, Jan. 2010.
- [5] M. Slepchenkov, K. Smedley, and J. Wen, "Hexagram-converter-based statcom for voltage support in fixed-speed wind turbine generation systems," *IEEE Trans. Ind. Electron.*, vol. 58, no. 4, pp. 1120–1131, Apr. 2011.
- [6] C. Han, A. Huang, M. Baran, S. Bhattacharya, W. Litzemberger, L. Anderson, A. Johnson, and A.-A. Edris, "Statcom impact study on the integration of a large wind farm into a weak loop power system," *IEEE Trans. Energy Convers.*, vol. 23, no. 1, pp. 226–233, Mar. 2008.
- [7] M. Molinas, J. Suul, and T. Undeland, "Extending the life of gear box in wind generators by smoothing transient torque with STATCOM," *IEEE Trans. Ind. Electron.*, vol. 57, no. 2, pp. 476–484, Feb. 2010.
- [8] J. Suul, M. Molinas, and T. Undeland, "STATCOM-based indirect torque control of induction machines during voltage recovery after grid faults," *IEEE Trans. Power Electron.*, vol. 25, no. 5, pp. 1240–1250, May 2010.
- [9] H. de Souza, F. Bradaschia, F. Neves, M. Cavalcanti, G. Azevedo, and J. de Arruda, "A method for extracting the fundamental-frequency positive-sequence voltage vector based on simple mathematical transformations," *IEEE Trans. Ind. Electron.*, vol. 56, no. 5, pp. 1539–1547, May 2009.
- [10] J. Hu, Y. He, L. Xu, and B. Williams, "Improved control of DFIG systems during network unbalance using PIR current regulators," *IEEE Trans. Ind. Electron.*, vol. 56, no. 2, pp. 439–451, Feb. 2009.



A NAVEEN KUMAR received his Bachelor Degree from priyadarshini institute of technology, tirupathi. He is doing his master degree in sri Venkatesa perumal college of engineering and technology, puttur.