

## **A variable speed wind turbine control strategy to wind farm grid code requirements**

S.Siva prasad <sup>1</sup> K.Vijayabhaskar <sup>2</sup> M.Kalaivani <sup>3</sup>

<sup>1</sup>(ELECTRICAL AND ELECTRONICS ENGINEERING,SVPCET, INDIA)

<sup>2</sup>(ELECTRICAL AND ELECTRONICS ENGINEERING,SVPCET, INDIA)

<sup>3</sup>(ELECTRICAL AND ELECTRONICS ENGINEERING,SVPCET, INDIA)

---

**ABSTRACT:** A fully operational multiterminal dc (MTDC) grid will play a strategic role for mainland ac systems interconnection and to integrate offshore wind farms. The importance of such infrastructure requires its compliance with fault ride through (FRT) capability in case of mainland ac faults. In order to provide FRT capability in MTDC grids, communication-free advanced control functionalities exploiting a set of local control rules at the converter stations and wind turbines are identified. The proposed control functionalities are responsible for mitigating the dc voltage rise effect resulting from the reduction of active power injection into onshore ac systems during grid faults. The proposed strategies envision a fast control of the wind turbine active power output as a function of the dc grid voltage rise and constitute alternative options in order to avoid the use of classical solutions based on the installation of chopper resistors in the MTDC grid. The feasibility and robustness of the proposed strategies are demonstrated and discussed in the paper under different circumstances.

**KEYWORDS:** Chopper resistor, fault ride through, HVDC, multi-terminal dc grids, offshore wind power.

---

### **I. INTRODUCTION**

The development of additional electrical interconnections is presently being planned by sea exploiting offshore grids, as it is documented in the European project “Twenties” and in the Intelligent Energy Europe projects “Off-shoreGrid” and “TradeWind”. In both cases, offshore interconnections are expected to provide two main requirements: the support to exchange power between ac areas and offshore wind power integration. The ac transmission of bulk power over long distances in offshore interconnections is technically limited by the high capacitance of shielded power cables. High-voltage direct current–voltage- source converter (HVDC–VSC) technology seems to be the most promising solution for offshore dc connections since it uses small harmonic filters, it allows the independent control of active and reactive power, bidirectional power flows, voltage support and it is able to provide black-start capability. Regarding HVDC transmission, multiterminal dc (MTDC) grids are foreseen as an alternative solution to point-to-point connections, providing higher flexibility, increased redundancy and reduction of maximum power not supplied to onshore grids in case of dc disturbances.

A fully operational MTDC grid with offshore wind farms (WF) can be regarded as a large (virtual) power plant capable of providing ancillary services to mainland ac grids. In this sense, it is expected that MTDC grids also provide fault ride through (FRT) capability for faults occurring in the mainland ac grid, in line with grid code requirements for onshore wind generators. The analysis and performance evaluation of different control solutions for the provision of FRT requirements in point-to-point HVDC systems equipped with VSC is discussed in . In any case, the dc voltage rise due to the onshore VSC power transfer reduction during the ac grid fault is the major concern for the development of any control strategy. In the authors propose five methodologies to dissipate/accommodate dc grid power in order to control the dc voltage rise. Excepting the solution based on the installation of dc chopper resistors, the other methodologies rely on a fast communication channel between onshore and offshore converter/wind turbine and involve: active power reduction output through offshore converter current control, wind turbine power set-point adjustment, offshore grid frequency adjustment and offshore ac grid voltage controlled reduction. In the authors propose a strategy to control the dc voltage rise during the ac grid fault by de-loading the offshore WF proportionally to the dc voltage rise. However, this strategy assumes the use of a communication link between the offshore converter and each wind turbine. Also, the installation of dc grid chopper resistor has been contemplated as an alternative. Although several authors assume the adoption of communication links for fast control within HVDC links, this solution may not comply with the restricted time-frame required to mitigate the dc voltage rise in case of mainland ac faults. Additionally, the specificity of MTDC grids increases the challenge for the implementation of communication networks for fast control actions. In general, a communication based solution demands for some coordination regarding the decision making process for the definition and assignment of power in-feed reductions in the MTDC nodes required to control the dc voltage rise. In this specific case, communication delays

or failures may cause unacceptable dc overvoltages, precluding the successful implementation of FRT capability.

To overcome the bottlenecks of communication-based solutions, this paper presents a new control philosophy to assure FRT compliance in MTDC grids: the implementation of a de-centralized control structure fully based on local controllers to be housed at HVDC–VSC stations and at the offshore wind turbines. The local control solutions aims to mitigate the dc voltage rise based on the fast control of wind turbine power output which is achieved through offshore grid voltage or frequency control strategies. The feasibility of the proposed control concepts are extensively demonstrated considering the most typical wind turbine technologies currently available: doubly fed induction generators (DFIG) and synchronous generators connected to the grid through a full converter. Following the use of the proposed control strategies under different circumstances, it is also demonstrated the avoidance of classical solutions based on the installation of additional equipment such as dc chopper re-sistors.

## II. HEADING S

- I. MODELING AND CONTROL OF MTDC GRIDS
  - A. DC GRID
  - B. HVDC CONVERTER
  - C. WIND GENERATOR MODEL
- II. PROPOSED APPROACHES FOR FRT PROVISION IN MTDC GRIDS
  - A. Onshore DC Chopper
  - B. *FRT Provision Through Wind Turbine Power Regulation*
- III. PERFORMANCE EVALUATION OF THE CONTROL STRATEGIES FOR FRT PROVISION IN MTDC GRIDS
  - A. Onshore Chopper Resistors
  - B. Offshore Wind Turbine Power Regulation Strategies
- IV. SENSITIVITY ANALYSIS
  - A. Evaluation of the Proposed Control Strategies in a Different MTDC Grid Topology
  - B. B. Evaluation of the Impact in the Offshore Converter Stations and Wind Turbines

## III. INDENTATIONS AND EQUATIONS

### II. MODELING AND CONTROL OF MTDC GRIDS

The MTDC grid provides the interconnection of “N” off-shore WF to “M” mainland collection points. In order to evaluate the dynamic behavior of the MTDC grid, including the HVDC–VSC stations and offshore WF, it is necessary to develop adequate models for simulating the operational characteristics of the overall system. Modeling system components will allow the identification of the most appropriate decentralized control strategies in order to provide FRT capability in MTDC grids. It is important to highlight that the major dynamic phenomena to be analyzed in this paper are associated to faults occurring in the mainland ac grid. Therefore, a RMS modeling approach is assumed, where losses, harmonics and fast switching transients of the converters are neglected. Taking into account this general consideration, the next sub-sections present a brief description of the adopted models.

#### A. DC Grid

The dc grid is assumed to be bipolar, being the dc cables represented by a concentrated parameter as it is suggested in [10]. Following this approach, the dc grid algebraic and State equations can be derived.

#### B. HVDC Converters

As previously mentioned, HVDC–VSC technology is assumed to be used in the MTDC grid, both at the onshore and offshore converter stations. From the onshore and offshore ac grid perspective, converter stations can be regarded as controllable voltage sources. The corresponding HVDC–VSC models and operational philosophies are presented hereafter.

**1) Offshore Converter:** The offshore WF is assumed to be connected to an ac grid, whose voltage and frequency are controlled by the offshore HVDC–VSC station. Simultaneously, the offshore converter interfaces the WF network with the MTDC grid. From the ac side, it performs as a slack bus for the ac off-shore grid by collecting all the generated power and delivering it to the dc grid. The main converter control loops are presented in Fig. 1. The converter model is implemented in the synchronous reference frame. The HVDC–VSC output voltages  $V_d$  and  $V_q$  values are set through PI controllers

Considering the voltage and current errors in the referred  $d$  and  $q$  reference frame.

**2) Onshore Converter:** The onshore HVDC-VSC is responsible for interfacing the MTDC grid to the ac onshore grid and for the control of the associated dc terminal voltage (which thereafter leads to the control of active power being injected into the onshore ac grid). The dc voltage reference can be defined through a local droop controller that can be expressed by

$$V_{DC\_ref} = V_{DC}^0 + k_{pv} \times P_{out} \quad (1)$$

Where  $P_{out}$  is the active power delivered by the HVDC\_VSC to the onshore ac grid,  $K_{pv}$  is a droop that relates the active power and dc voltage variations and  $V_{DC}^0$  is configurable parameter that can be adjusted in order to modify the steady-state power sharing between converters. This converter was also modelled in the synchronous reference frame through its main control loops, which are depicted in Fig. 2. The converter output voltages  $V_d$  and  $V_q$  are set through PI controller associated to the converter inner current control loop, the converter outer control loop provide the  $i_{d-ref}$  current reference through the error generator between the actual dc voltage and the reference dc voltage; the  $i_{d-ref}$  current reference is provided by PI another regulation loop that can be used for setting converter reactive power or output voltage. For this specific case, the regulation was set to control the ac voltage magnitude at the VSC ac terminals.

**3) HVDC-VSC Current Limiting:** From an operation point of view, HVDC-VSC technology is able to remain connected to the ac grid during low voltage sags. Nevertheless, power electronic converters have a maximum current limit associated with the thermal characteristics of the power electronic switches. However, short overcurrents are admissible in the power converters (in, around 8% overcurrent capacity is assumed). Considering that during a fault a certain re-active current component  $i$  is to be injected by the converter. These limits were implemented in the current control loops of each converter station.

### C. Wind Generator Model

Regarding the offshore WF, two most common generator technologies with FRT capability were considered in order to demonstrate that the FRT control schemes for the MTDC grid proposed in this paper are effective. For the first case, offshore WF were assumed to be equipped with permanent-magnet synchronous generators (PMSG) interfaced with the ac offshore grid via an ac/dc/ac full converter. For this case a lumped model was adopted according to the approach described in. For the second case, offshore WF were assumed to be equipped with DFIG, which are modeled according to the approach presented in. The control approach discussed in is able to effectively reduce the transient rotor and stator currents in DFIG by allowing a controlled increase of the rotor speed following a voltage sag, thus improving its FRT performance.

## II. PROPOSED APPROACHES FOR FRT PROVISION IN MTDC GRIDS

The converter current limits are responsible for reducing the onshore HVDC-VSC active power injection capability during voltage sags. Offshore WF commonly operate in a maximum power extraction philosophy and offshore HVDC-VSC injects the incoming power into the dc grid. Therefore, during an ac mainland fault, a significant power reduction occurs in the HVDC-VSC terminal connected to the faulted area. Without the use of any specific strategy (which are addressed hereafter), the offshore WF will remain operating under a maximum power extraction strategy. Consequently, the dc power imbalance will result on dc overvoltages in the different MTDC grid nodes depending on the pre-disturbance active power flows and on the MTDC grid topology. Nonetheless, dc overvoltages must be controlled in order to avoid equipment damages and provide the expected flexibility in terms of FRT capability. In order to mitigate the dc voltage rise effect, three control strategies are proposed and tested. The first one consists on a conventional solution based on dc chopper resistors installed at onshore VSC-level and is considered as a reference case. The other two strategies rely on innovative communication-free solutions that exploit the control flexibility of both offshore HVDC-VSC converter stations and wind generators to perform fast active power reduction at the wind generator level. These control strategies are based on the implementation of local control rules at offshore converter stations and at wind turbine generators and are intended to avoid the use of solutions based on dc chopper resistors.

### A. Onshore DC Chopper

A dc chopper consists on a dc resistor controlled through a power electronic switch and it is installed at the HVDC-VSC onshore converter station as it is depicted in Fig. 3. A detailed sizing of a dc chopper-based solution for FRT compliance in MTDC grids is out of the scope of this paper (as previously mentioned, this type of solution is considered only as a reference case). Nevertheless, it depends on several factors, namely the MTDC grid power in-

feeds (power in-feeds from offshore WF or from other mainland ac grid areas) as well as on the mainland grid connection points and its electrical distance. In this case, a simple approach based on a worst case scenario was considered. The worst case condition corresponds to a situation where all HVDC–VSC stations are operating at the nominal power. In case of a fault, healthy converters (connected to non-faulted ac mainland grids) are not able to increase their power injection and power dissipation in chopper resistors is required in order to mitigate the dc voltage rise. Based on this assumption, each dc chopper must be sized to dissipate the nominal power of the HVDC–VSC to which it is connected. The activation of each dc chopper control strategy is based on a dc voltage threshold that will trigger power dissipation in the resistor. In terms of RMS system modeling, the dc chopper active power dissipation is locally regulated based on a proportional control rule having as input the positive dc voltage deviation (overvoltage magnitude). The dc chopper de-activation occurs if: (1) the dc voltage reaches a value below the threshold activation level (eg.: after fault clearance) or; (2) the chopper resistor temperature overreaches the maximum value (thermal protection tripping), meaning that the resistor maximum energy dissipation capability has been overreached. This specific situation is often related to a permanent fault event and must be handled by additional control schemes to perform permanent active power reduction at offshore WF-level.

### B. FRT Provision Through Wind Turbine Power Regulation

Modern wind turbines connected to ac grids in onshore applications are FRT compliant, coping with the requirements of many grid codes. However, MTDC grids decouple the offshore WF and the onshore ac grid. Therefore, in order to derive a communication-free solution to provide FRT in MTDC grids, strategies exploiting the dc overvoltages resulting from onshore ac faults can be advantageous. The main objective is the implementation of local controllers at the offshore VSC and at the wind generators enabling them to perform fast active power regulation as it is generally depicted in Fig. 4. The envisioned control strategies exploit MTDC grid voltage rise in order to control

(1) the offshore ac grid voltage or (2) the offshore ac grid frequency.

**1) Wind Turbine Power Regulation Based on Offshore AC Grid Voltage Control:** The dc voltage rise can be used in order to control the magnitude of the ac output voltage of the offshore HVDC–VSC. Therefore it is suggested to include a local control at the HVDC–VSC station that proportionally decreases the ac voltage as a function of the dc voltage rise in the converter dc terminal:

$$V_{AC} = V_{AC_{ref}} - k_{DC/AC} \times (V_{DC_{ref}} - V_{DC}) \quad (2)$$

where  $V_{AC}$  is the offshore ac voltage magnitude,  $V_{AC_{ref}}$  is the ac voltage magnitude reference,  $k_{DC/AC}$  is the droop gain that adapts the dc to the ac offshore voltage,  $V_{DC_{ref}}$  is the steady state dc voltage reference and finally  $V_{DC}$  is the actual dc voltage magnitude. With the use of this strategy, wind generators will

be able to react to the offshore ac grid undervoltage and quickly reduce the injected active power.

In addition to FRT capability, it is also common that wind generators installed in onshore WF are requested to inject reactive current to support grid voltage in case of a fault. In this case, and in order to successfully implement the wind generators' power regulation based on offshore ac grid voltage control, the wind generators must not inject reactive current when decreasing the offshore ac voltage as a function of the dc voltage rise. Otherwise, it may lead to offshore voltage support that precludes the application of the envisioned control strategy.

**2) Wind Turbine Power Regulation Based on Offshore AC Grid Frequency Control:** The dc voltage rise can be used in order to control the frequency of the offshore HVDC–VSC ac output voltage. In this case, it is suggested to include a local control at the offshore HVDC–VSC station that proportionally increases the ac grid frequency as a function of the dc voltage rise in the associated dc converter terminal:

$$f_{offshore} = f_{ref} + k_{DC/f} \times (V_{DC_{ref}} - V_{DC}) \quad (3)$$

where  $f_{offshore}$  is the actual offshore frequency,  $f_{ref}$  is the reference value for offshore frequency,  $k_{DC/f}$  is the droop gain that adapts dc voltage to offshore frequency variation. This control scheme is to be complemented at the wind generator level with a control loop that provides a fast generator power reduction as a function of the offshore ac grid frequency increase. A first order time constant is used in order to take into consideration the HVDC–VSC converter station response time with respect to frequency variations. A detailed analysis regarding the impacts of this time constant on the performance of the control strategy based on

offshore grid frequency variations is addressed in Section V.

**3) Local Controls at the Wind Generator Level:** As previously mentioned, PMSG and DFIG were assumed to be used in offshore WF in order to demonstrate the feasibility and evaluate the performance of the proposed wind generators' active power control strategies. Regarding PMSG, the wind generator local control for fast active power regulation is set to dissipate active power proportionally to ac offshore grid voltage (case 1) or frequency variations (case 2). To achieve a fast response, it is assumed the power dissipation is made at the wind generator chopper resistor installed on the dc busbar of the ac-dc-ac full converter, while having the advantage of keeping the generator side decoupled from the transient phenomena.

For the DFIG, the active power regulation is naturally achieved for the ac voltage regulation strategy, since the controlled voltage sag in the offshore ac grid leads to the generator demagnetization, increasing slightly its angular speed and consequently reducing the injected power. In this case, inrush currents resulting from the demagnetization of DFIG are a critical issue due to the current limits of the HVDC-VSC station connected to the offshore ac grid. In order to overcome this drawback, the control strategy presented in is adopted, as it was previously mentioned. Compared to conventional DFIG control strategies, it presents the advantage of assuring a considerable limitation of the stator currents following the voltage dip, while limiting also the rotor current and avoiding the need of the crowbar. The control principle exploits the possibility of allowing the DFIG rotor speed increase in coordination with the control of the wind turbine pitch angle in order to limit the acceleration phase and to avoid stability issues.

Regarding the frequency-based active power regulation strategy in the DFIG, a supplementary control is used in the speed control loop implemented in the rotor side converter which allows a rotor speed increase to achieve a fast reduction of active power generation.

#### IV. PERFORMANCE EVALUATION OF THE CONTROL STRATEGIES FOR FRT PROVISION IN MTDC GRIDS

In order to characterize the MTDC grid operational issues when performing FRT and to evaluate the impacts and the performance of the local control strategies, the test system was used. It consists of two non-synchronous onshore ac areas represented by a single machine equivalent bus that collects offshore power from a four terminal H-topology MTDC grid including two offshore WF. A full characterization of the test system can be found in [10]. Each offshore WF (either equipped with PMSG or DFIG generators) was modelled by a single equivalent machine with a power production of 200 MW. Each HVDC-VSC station has a nominal apparent power of 250 MVA. The test system was fully modelled in a Matlab/Simulink simulation platform, according to the dynamic models of the components that were previously described.

In order to characterize the transient overvoltage phenomena in MTDC grids, a 500 ms three-phase fault was simulated near Area #1 onshore converter ac terminals at  $t = 1$  s. The most important results are presented in Figs. 6 and 7. The time evolution of the active power in each HVDC-VSC terminal shows that during the fault Area #1 onshore converter reduces the capability of exporting about 160 MW. In contrast, the onshore converter in Area #2 was able to increase the power transmission in about 50 MW. This behavior is related with the previously presented dc voltage/active power droop control  $k$  which regulates the active power extraction as a function of the dc voltage variations. However, it is notorious that active power dynamics in the Area #2 converter is slower than the corresponding time constant observed in the active power reduction in Area #1 converter. Regarding the dc voltage behavior, the obtained results on each MTDC grid terminal are depicted in Fig. 7. Onshore converter in Area #1, offshore WF #1 and WF #2 have a similar behavior. The Area #2 onshore converter dc terminal voltage differs from the previous since the associated converter extracts power following the dc voltage/active power droop control and keeps the dc voltage in a lower value. The dc overvoltage takes a magnitude over 1.5 p.u. which is greater than the maximum admissible value that was considered  $\pm 1.2$  p.u. This effect should be controlled in order to prevent damaging components such as cable circuits, dc capacitor banks and also the VSC.

In order to mitigate the dc overvoltages, it is necessary to exploit control mechanisms that are able to effectively provide active power balance within the dc grid. In order to establish a comparative analysis, the same test case and fault condition is considered in the simulation results that are presented next.

##### A. Onshore Chopper Resistors

In order to define a reference case, the first analysis consisted on evaluating the behavior of MTDC grid, namely regarding dc voltage profile and active power flows, when the FRT capability is to be assured through the use of two dc choppers installed on each dc onshore terminal. The obtained results are depicted in Figs. 8 and 9, where it is possible to observe that a small dc overvoltage took place during fault occurrence. However, its magnitude was controlled, being much lower than in the previous case and it reaches a peak value below the maximum admissible overvoltage (1.2 p.u.).



From the simulation results illustrated in Fig. it is possible to conclude that dc voltage rise is controlled by additional power dissipation in the dc chopper located at the dc side of the onshore VSC connected to Area #1. In the other onshore terminal—the VSC connected to the Area #2—the active power delivery slightly increases due to a small dc voltage increase. Simultaneously, as a result of the small dc voltage increase, the associated Area #2 dc chopper is contributing with negligible power dissipation. It is important to note that for this specific set of simulations, offshore WF have not change their power injection since, as aforementioned, the dc grid decouples the interconnected ac areas and the dc power balance is achieved through external solutions in relation to the WF.

### **B. Offshore Wind Turbine Power Regulation Strategies**

The two regulation mechanisms for wind turbine power reduction in the moments subsequent to a mainland ac fault (ac offshore voltage reduction and ac offshore frequency increase) are illustrated in two distinct scenarios: 1) both WF equipped with PMSG and 2) both WF equipped with DFIG. A detailed analysis of other operating conditions as well as on the stress regarding converter stations and wind turbines is presented in Section V.

**1) Offshore AC Voltage Reduction:** The results obtained through offshore ac voltage control for wind turbine power reduction are depicted in Figs. it is possible to observe that the offshore ac voltage reduction is successfully achieved for both scenarios (WF equipped with PMSG and with DFIG). However, a difference on the ac voltage behavior is also noticeable. This fact is related with the natural response of each generator regarding the voltage reduction. The PMSG quickly dissipates active power on its own dc chopper (previously referred as wind turbine chopper). On contrast, the DFIG reduces power naturally due to the terminal voltage drop (generator demagnetization). The evolution of DFIG speed is also depicted in Fig. and it can be verified that the generator speed increases as a result of the voltage sag that reduces the electromagnetic torque of the generator. In Figs. it is possible to verify that the aforementioned power reduction is accomplished on both WF. As a result, the dc voltage profile rise is controlled and reaches a peak value below the maximum admissible overvoltage.

**2) Offshore AC Frequency Increase:** The alternative scheme for power reduction at offshore level is based on the WF ac grid frequency control proportionally to the dc voltage increase. This strategy was also tested for WF equipped with PMSG and DFIG. The major results are presented on Figs. The results depicted in Fig. allow concluding that frequency increase has been successfully accomplished on the offshore WF ac grid for both cases. It is also observable by the frequency behavior that DFIG-based WF has a bigger settling time comparing to the PMSG-based WF. This fact is related with the DFIG speed control that is used in order to achieve a fast active power reduction in the moments subsequent to the ac fault. Regarding the power-flow behavior depicted in Fig. it can be observed that both WF are able to reduce the power injection to the dc grid during the fault occurrence. However, after fault clearance the PMSG-based WF is able to quickly restore the pre-fault power injection value. In contrast, DFIG-based WF takes more time to attain the pre-fault power level. This fact can be justified by the control used on the DFIG generators which acts on the machine speed by increasing it to reduce the torque and consequently reduce the active power injection. This procedure has a higher time constant when compared to the chopper power dissipation used on PMSG generators. With respect to the dc voltage profiles depicted in Fig. the implemented control strategies assure that both WF respond to the frequency increase in their own grids in order to reduce the power production. Simulation results also shows the DFIG response time is not problematic from the dc voltage rise perspective as the dc voltage was kept below the maximum admissible value (1.2 p.u.). From the overall results obtained with respect to the MTDC system presented in Fig. , it is possible to conclude that all the strategies (using dc chopper resistors or WF active power regulation), which share the characteristic of not relying on communication networks for its implementation, demonstrate to be effective regarding the mitigation of dc transient overvoltage that precludes the FRT functionality following a mainland ac grid fault. Moreover, the simulation results also demonstrates that the WF active power regulation strategies do not require the adoption of additional equipment at the MTDC grid level such as the chopper resistors, thus constituting an alternative solution to it.

## **V. SENSITIVITY ANALYSIS**

In order demonstrate the effectiveness of the proposed control strategies based on fast active power control at the WF level, an additional MTDC grid topology incorporating different types of WF was considered and it is depicted in Fig. The new test system is assumed to be connected at the same mainland ac grid and includes two offshore WF equipped with different wind generator technologies: DFIG in WF #1 and PMSG with a full converter in WF #2. Such configuration consists on a severe case regarding an ac mainland fault, since both onshore HVDC-VSC converters will be affected by the voltage sag. In addition to the demonstration of the proposed strategies in a different MTDC grid, next subsections provide also a sensitivity analysis with respect to several control parameters regarding its impact on the MTDC grid voltage rise as well as on HVDC-VSC and wind turbines stress. Given the natural response of a DFIG, special attention is given to HVDC-VSC current and to DFIG speed when performing WF active

power control.

### A. Evaluation of the Proposed Control Strategies in a Different MTDC Grid Topology

In this case, it was assumed that both WF were injecting their maximum power (200 MW). It was also considered that the HVDC-VSC converter connected to the DFIG-based WF will perform offshore ac grid frequency control for WF active power regulation. Conversely, the HVDC-VSC converter connected to the PMSG-based WF will perform offshore ac grid voltage control for WF active power regulation. Through the adjustment of  $V_0$  at each onshore HVDC-VSC, the pre-disturbance power injection into the mainland ac grid consisted on about 250 MW at VSC #1 and 150 MW at VSC #2. Similarly to the previous case, the onshore HVDC-VSC were considered to have a maximum capacity of 250 MVA. A 500 ms three-phase fault was simulated in the mainland ac grid at  $t=1$  s. The most important results are presented in the next figures, where it is also possible to observe the influence of the droop parameters used in offshore HVDC-VSC frequency and voltage regulation strategies according to the set of parameters presented in Table I.

From the analysis of the presented results, it is possible to conclude that the proposed control solutions are able to provide the required FRT functionality in a different MTDC grid topology comprising both a meshed and a radial part. Additionally, the results demonstrate that different active power regulation strategies can be used in different offshore WF, thus demonstrating the robustness of the envisioned control solutions. The obtained results also support the conclusion that a communication-free control solution for fast active power regulation at the WF level is able to avoid the use of additional equipment such as dc chopper resistors to assure the MTDC grid FRT capability. When analyzing Figs. 17 and 18, it is possible to conclude that the proper selection of offshore HVDC-VSC droop control parameters can be used to differently share the responsibility of the active power regulation at the offshore WF. Simultaneously, it can be observed in Figs. 18 and 20 that the effect resulting from the selection of different droop control parameters does not compromise MTDC grid overvoltage control and guarantees the provision of FRT capability from the MTDC grid.

### B. Evaluation of the Impact in the Offshore Converter Stations and Wind Turbines

As a pre-fault condition, it was assumed both WF were injecting their maximum power (200 MW), while onshore converter stations equally share the power injection to the mainland ac grid. A 500 ms three-phase fault was simulated in the mainland ac grid at  $t=1$  s, being the corresponding results presented in Figs. 17 and 18. In this case, WF #2 (equipped with PMSG) is set to reduce active power through a frequency control strategy implemented in the corresponding offshore converter station (being the associated  $K_{DCf}$ —pu volt/Hertz—droop constant). WF #1 (equipped with DFIG generators) is set to reduce active power through a voltage control strategy implemented in the corresponding offshore converter station. In order to evaluate the stress in the DFIG wind turbines and in the associated offshore converter, the impact of different droop control parameters ( $K_{DCAC}$ —pu volt/pu volt) was tested:  $K_{DCAC}=1$  (Case A),  $K_{DCAC}=2$  (Case B) and  $K_{DCAC}=3$  (Case C). All cases demonstrate that both WF effectively share the power reduction in order to be possible to mitigate the MTDC grid voltage rise effect following the mainland grid fault. As it can be observed in Fig. 22, increasing the  $K_{DCAC}$  droop leads to more pronounced voltage drops in the offshore grid, as well as to higher active power reductions in the DFIG generators. Consequently, it is possible to observe the increase of the DFIG speed. However, the adopted DFIG control strategy allows to effectively avoid the inrush currents following the voltage drop. In the moments subsequent to fault elimination, the offshore grid voltage recovered and the DFIG rotor controller recovers the speed to the pre-fault condition. During this stage, small overcurrents are observed (less than 5%) in the DFIG, and consequently in the offshore HVDC-VSC (which is in line with the assumed overcurrents in Fig. 22). In the PMSG (WF #1), the power control is based on power dissipation in the internal chopper of the generator, while the ac/dc/ac interface assures full current control, thus not leading to overcurrent situations. Therefore, the PMSG remains fully decoupled from the offshore grid, not being affected by the fault. The impact of the time constant associated to the frequency control strategy used in offshore HVDC-VSC for fast active power control in the WF was also evaluated. In this case, the operational scenario previously described was considered, being both WF set to regulate the active power output based on the offshore grid frequency. A time constant of 25 ms, 50 ms and 100 ms were tested. The obtained results are illustrated in Fig. 23. Up to a time constant of 100 ms, the proposed control strategy is able to mitigate the voltage rise effect in the MTDC grid and assures it does not overpass the pre-defined threshold (1.2 p.u.). Regarding DFIG, it is possible to observe its speed increase in order to achieve a fast reduction in the output power. In the moments subsequent to mainland ac fault clearance, the offshore ac grid starts to recover and it is possible to observe a small overcurrent in the DFIG while its speed returns to the pre-fault conditions. The observed overcurrent is similar to the one obtained for the case where DFIG power output is controlled based on the offshore ac grid voltage.

IV. FIGURES AND TABLES

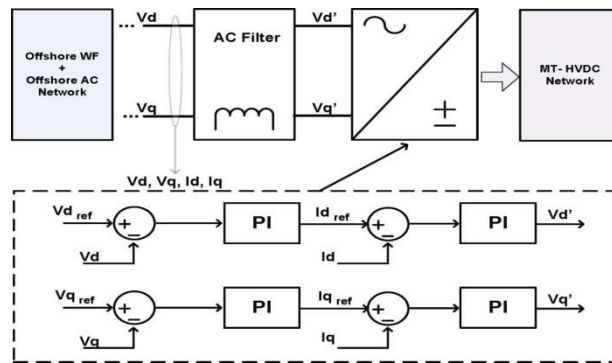

Fig. 1. Internal control loops of the offshore converters

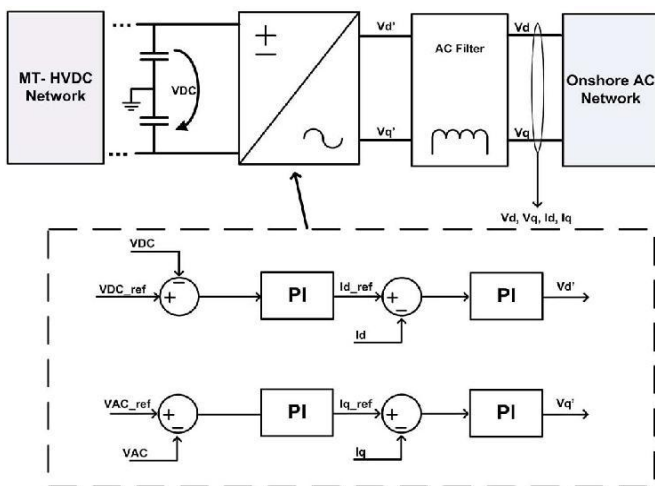

Fig. 2. Internal control loops of the onshore converters

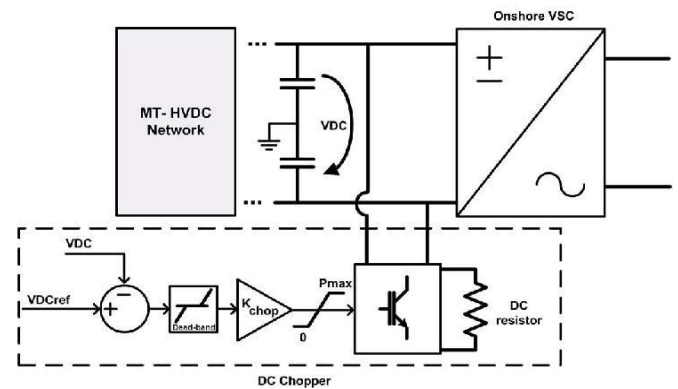

Fig. 3. Control scheme of onshore dc chopper

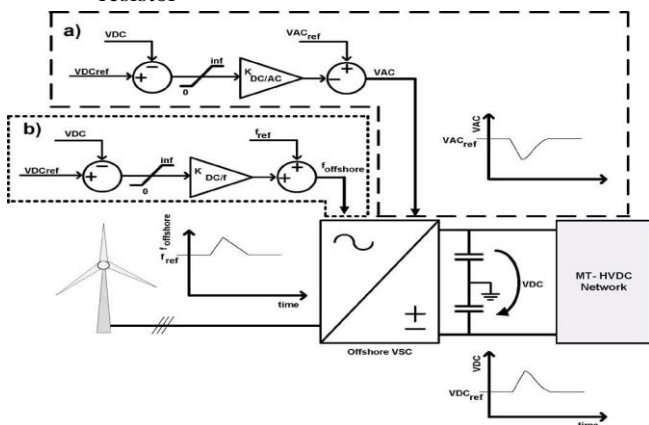

Fig. 4. Control scheme for FRT provision based on dc voltage:  
 (a) AC offshore grid voltage control. (b) AC offshore grid frequency control.

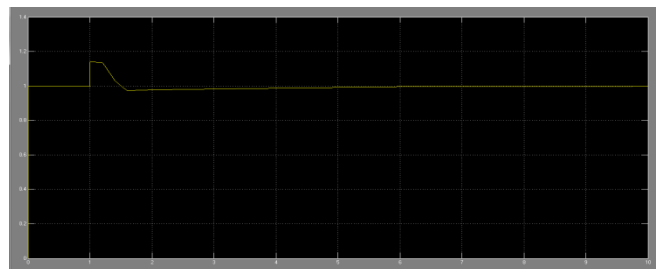

Fig.5. DC voltage profile at the MTDC grid terminals with on-shore chopper resistor



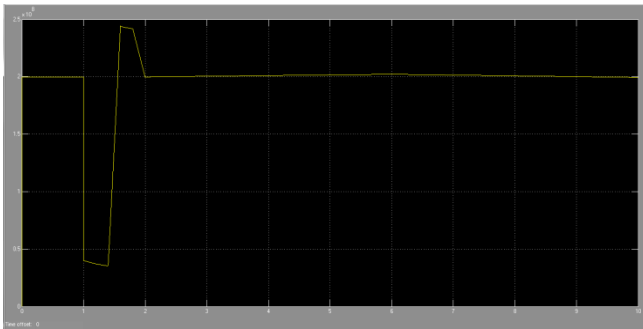

Fig 6; active power flow at the mtdc grid terminals

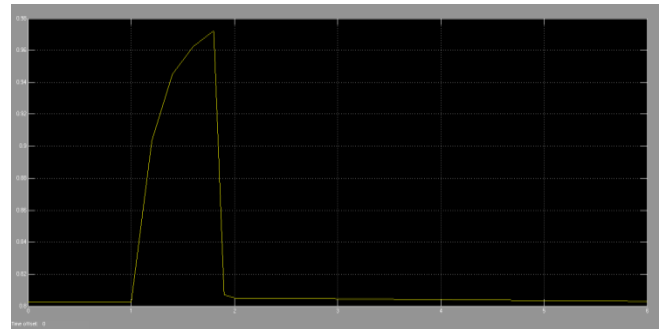

Fig.7 Regulated frequency and voltage at off-shore HVDC-VSC station

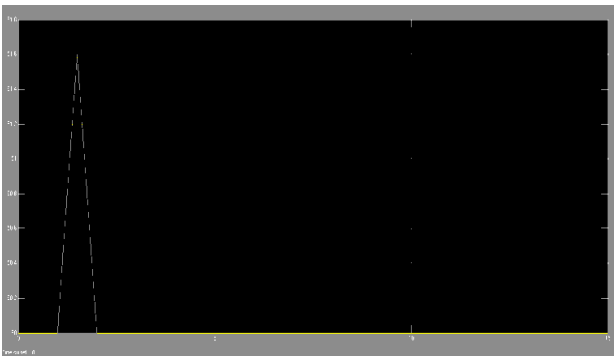

Fig. 8 MTDC grid voltage profile and PMSG-based WF response with respect to the variation of the  $K_{DC/AC}$  Dr

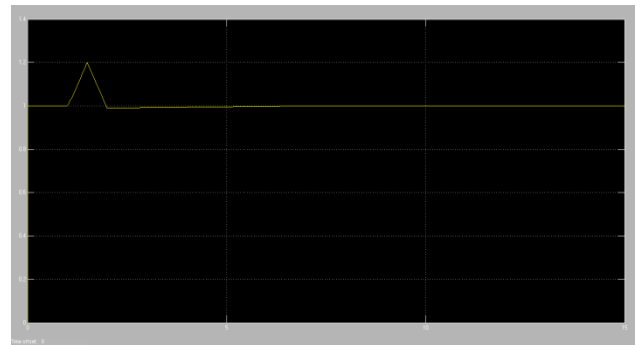

Fig. 9 Impact of the frequency control time delay in the DFIG-based WF

TABLE - I  
 OFFSHORE HVDC-VSC FREQUENCY AND VOLTAGE DROOP CONTROL PARAMETER

	$K_{DC/AV}$ (pu volt /pu volt)	$K_{DC/r}$ (pu volt/hertz)
Case A	-2	5
Case B	-4	2.5

## V. CONCLUSION

This paper provides a discussion on the identification and development of communication-free control strategies for FRT provision on MTDC grids interconnecting offshore WF with ac mainland grids. The proposed control strategies for endowing MTDC grids with FRT capability share a common characteristic: the accommodation/dissipation of active power from off-shore WF in order to mitigate the dc voltage rise effect. The classical solution based on the use of onshore chopper resistors is an effective solution that can be easily implemented since its control is based on local measurements. Although the use of such strategy fully decouples offshore WF from the main-land ac fault, which is benefic regarding the reduced stress conditions for the wind turbines, the size of the required dc chopper resistors may hinder its application from an economical point of view.

Alternative approaches for the mitigation of MTDC over-voltages are based on active power reduction at the turbine level throughout the exploitation of a communication-free control strategy which is based on a set of local controllers to be installed at the offshore converter station and at the wind turbine level. The proposed strategies are effective regarding active power regulation in order to assure FRT compliance from MTDC grids.

The achieved results allow concluding that proposed control strategies are robust under very stressful conditions, are independent of the dc grid topology and of the pre-disturbance dc grid power dispatch. This is a key requirement towards the interoperability of solutions from different manufacturers. The major advantage of these strategies relies on less investment regarding the implementation of the required control functionalities. However, these strategies lead to some stress over DFIG in terms of speed variations (similarly to what happens in wind turbines connected to onshore grids). Also, small overcurrents are observed in the associated HVDC-VSC and must be considered in the design phase.

## REFERENCE

- [1]. European Union Project TWENTIES. [Online]. Available: <http://www.twenties-project.eu> Oct. 2012
- [2]. K. Bell, D. Cirio, A. M. Denis, L. He, C. C. Liu, G. Migliavacca, C. Moreira, and P. Panciatici, "Economic and technical criteria for designing future off-shore HVDC grids," in *Proc. Power Energy Soc. In-novative Smart Grid Technol. Conf. Eur.*, 2010, pp. 1–8.
- [3]. Intelligent Energy Europe. OffshoreGrid Project, 2012. [Online]. Available: <http://www.offshoregrid.eu/>
- [4]. Intelligent Energy Europe. Tradewind Project, 2012. [Online]. Available: <http://www.trade-wind.eu>
- [5]. T. Ackermann, "Transmission systems for offshore wind farms," *IEEE Power Eng. Rev.*, vol. 22, no. 12, pp. 23–27, Dec. 2002.
- [6]. N. B. Negra, J. Todorovic, and T. Ackermann, "Loss evaluation of HVAC and HVDC transmission solutions for large offshore wind farms," *Elect. Power Syst. Res.*, vol. 76, no. 11, pp. 916–927, 2006.
- [7]. N. Flourentzou, V. G. Agelidis, and G. D. Demetriades, "VSC-based HVDC power transmission systems: An overview," *IEEE Trans. Power Electron.*, vol. 24, no. 3, pp. 592–602, Mar. 2009.
- [8]. O. Gomis-Bellmunt, J. Liang, J. Ekanayake, R. King, and N. Jenkins, "Topologies of multiterminal HVDC-VSC transmission for large off-shore wind farms," *Elect. Power Syst. Res.*, vol. 81, no. 2, pp. 271–281, 2011.
- [9]. O. Gomis-Bellmunt, J. Liang, J. Ekanayake, and N. Jenkins,
- [10]. "Voltage—current characteristics of multiterminal HVDC-VSC for offshore wind farms," *Elect. Power Syst. Res.*, vol. 81, no. 2, pp. 440–450, 2011.
- [11]. S. Cole, J. Beerten, and R. Belmans, "Generalized dynamic VSC MTDC model for power system stability studies," *IEEE Trans. Power Syst.*, vol. 25, no. 3, pp. 1655–1662, Aug. 2010.
- [12]. B. Silva, C. L. Moreira, L. Seca, Y. Phulpin, and J. A. P. Lopes, "Pro-vision of inertial and primary frequency control services using offshore multiterminal HVDC networks," *IEEE Trans. Sustain. Energy*, vol. 3, no. 4, pp. 800–808, Oct. 2012.
- [13]. M. Tsili and S. Papathanassiou, "A review of grid code technical requirements for wind farms," *IET Renew. Power Gen.*, vol. 3, no. 3, pp. 308–332, 2009.
- [14]. F. D. Bianchi, O. Gomis-Bellmunt, A. Egea-Alvarez, and A. Junyent-Ferre, "Optimal control of voltage source converters for fault operation," in *Proc. 14th Eur. Power Electron. Appl. Conf.*, Aug. 30–Sep. 1, 2011, p. 1, 10.
- [15]. T. D. Vrionis, X. I. Koutiva, N. A. Vovos, and G. B. Giannakopoulos, "Control of an HVDC link connecting a wind farm to the grid for fault ride-through enhancement," *IEEE Trans. Power Syst.*, vol. 22, no. 4, pp. 2039–2047, Nov. 2007.
- [16]. C. Feltes, H. Wrede, F. W. Koch, and I. Erlich, "Enhanced fault ride-through method for wind farms connected to the grid through VSC-based HVDC transmission," *IEEE Trans. Power Syst.*, vol. 24, no. 3, pp. 1537–1546, Aug. 2009.
- [17]. G. Ramtharan, A. Arulampalam, J. B. Ekanayake, F. M. Hughes, and N. Jenkins, "Fault ride through of fully rated converter wind turbines with AC and DC transmission," *IET Renew. Power Gen.*, vol. 3, no. 4, pp. 426–438, 2009.
- [18]. L. Xu and L. Yao, "DC voltage control and power dispatch of a multi-terminal HVDC system for integrating large offshore wind farms," *IET Renew. Power Gen.*, vol. 5, no. 3, pp. 223–233, 2011.
- [19]. O. Gomis-Bellmunt, A. Egea-Alvarez, A. Junyent-Ferre, L. Jun, J. Ekanayake, and N. Jenkins, "Multiterminal HVDC-VSC for offshore wind power integration," in *Proc. IEEE Power Energy Soc. Gen. Meeting*, 2011, pp. 1–6.
- [20]. L. Jun, J. Tianjun, O. Gomis-Bellmunt, J. Ekanayake, and N. Jenkins, "Operation and control of multiterminal HVDC transmission for offshore wind farms," *IEEE Trans. Power Del.*, vol. 26, no. 4, pp. 2596–2604, Oct. 2011.