

# Three Phase Three Level DC/DC Converter Using Active Clamp Circuit

K. Ravindra Varma

*PG.Scholar*

*Department of Electrical and Electronics Engineering*

*Sri Venkatesa Perumal College of Engineering and Technology, Puttur.AP India*

T. Hari

*Assistant Professor*

*Department of Electrical and Electronics Engineering*

*Sri Venkatesa Perumal College of Engineering and Technology, Puttur.AP, India*

---

**Abstract:** Three-phase dc/dc converters have the superior characteristics including lower current rating of switches, the reduced output filter requirement, and effective utilization of transformers. To further reduce the voltage stress on switches, three-phase three level (TPTL) dc/dc converters have been investigated recently; however, numerous active powers switches result in a complicated configuration in the available topologies. Therefore, a novel TPTL dc/dc converter adopting a symmetrical duty cycle control is proposed in this paper. Compared with the available TPTL converters, the proposed converter has fewer switches and simpler configuration. The voltage stress on all switches can be reduced to the half of the input voltage. Meanwhile, the ripple frequency of output current can be increased significantly, resulting in a reduced filter requirement.

**Key words:** Three phase three levels (TPTL), Three Phase, DC/DC Converter

---

## 1. Introduction

Full bridge dc/dc converters have been used widely in the medium-to-high power applications for the pulse width modulation (PWM) control, soft-switching characteristics, and lower power rating on switches. To further reduce the power rating on switches, a prominent three-phase full-bridge topology was introduced in which three phase bridges consisting of six switches and a three-phase transformer are adopted. A three-phase transformer with -Y connection is employed for the smaller turn's ratios and transformer VA rating. With the three-phase architecture, the converters have the features including lower current rating of switches, reduced input and output current ripple allowing small-size filter requirement, and better utilization of transformer core. It is essentially derived from the neutral point clamped (NPC) inverter which can reduce the voltage stress of the power switches to only a half of the input voltage, when compared with traditional topologies. Three-phase three-level (TPTL) PWM dc/dc converters were proposed in this converter composed of an NPC inverter connected to the primary side of a three-phase high-frequency transformer. The secondary side of the transformer feeds a three-phase rectifier, and the output stage of the converter is composed of the output filter and the load. The symmetrical duty cycle control was adopted in the converter, and the converter has the features including lower voltage stress on switches, soft switching capabilities and voltage source characteristic for output stage.

## 2. Methodology

To simplify the circuit configuration, a novel TPTL converter is proposed in this paper, which keeps the advantages of the available TPTL converters including the lower voltage stress, efficient utilization for transformer, and reduced output filter requirement; meanwhile, the number of switches is reduced significantly, along with the gate drivers and PWM channels, resulting in a simpler architecture and lower cost. To maximize the overall efficiency an Active Clamp Technology are used in the rectifier side.

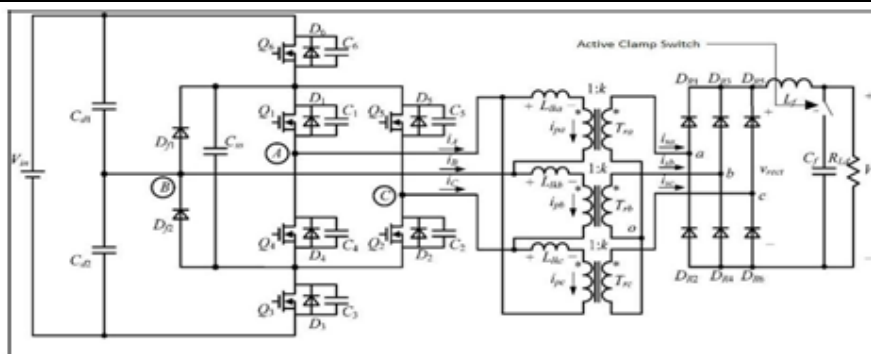

Figure 1: Circuit Diagram of TPTL dc/dc converter

An active snubber, which consists of an active switch and a capacitor, has to switch at twice the switching frequency and at the full power of the main dc/dc converter. This Active Clamp Technology will reduce the duty cycle losses. It reduces the number of switches, the gate drivers, and PWM channels significantly, which greatly simplifies the circuit structure. All power switches sustain only half of the input voltage. The output filter inductance is significantly reduced. The current stress of the switches is reduced due to the three-phase configuration.

The three-phase transformer with -Y connection is employed for the smaller turn's ratios and transformer VA rating.  $Q_1$ ,  $Q_3$ , and  $Q_5$  are switched ON in turn according to the rising edge of the clock signals with interval of one-third switching period; the duty cycles of  $Q_1$ ,  $Q_3$ , and  $Q_5$  are modulated by the comparison between three same carrier signals and the error signal. The gate signals of  $Q_4$ ,  $Q_6$ , and  $Q_2$  are interleaved with  $Q_1$ ,  $Q_3$  and  $Q_5$  by a half switching period, respectively. The three phase full-bridge converter can be viewed as a combination of two full-bridge sections sharing a common bridge leg. In the full-bridge section composed of  $Q_1$ ,  $Q_3$ ,  $Q_4$ , and  $Q_6$ ,  $Q_6$  is turned ON leading to  $Q_1$ , and  $Q_3$  is turned ON leading to  $Q_4$ , as depicted in Fig.1 According to the correspondence between two converters, the full-bridge section composed of  $Q_1$ ,  $Q_3$ ,  $Q_4$ , and  $Q_6$  can be replaced by a half bridge TL section directly, and the transformer and secondary stages remain unchanged. Therefore, a novel TPTL converter can be derived, as shown in Fig. 1.  $C_{d1}$  and  $C_{d2}$  are large enough and they share evenly the input voltage, i.e.,  $V_{Cd1} = V_{Cd2} = V_{in} / 2$ .  $L_{lka}$ ,  $L_{lkb}$ , and  $L_{lkc}$  are the equivalent primary leakage inductances of each phase.  $D_{f1}$  and  $D_{f2}$  are freewheeling diodes.  $C_{ss}$  is the flying capacitor, which is in favor of decoupling the switching transition of  $Q_1$ ,  $Q_3$ ,  $Q_4$ , and  $Q_6$ .  $DR1-DR6$  are rectifier diodes. The output filter is composed of  $L_f$  and  $C_f$ , and  $R_{Ld}$  is the load.

The DC source is given to a three level inverter, where it gets converted to AC. The output of a three level inverter is given to the three phase transformers. Then the output of the 3 phase transformers is given to the three phase rectifier. In three phase rectifier the AC is converted to DC and they are given to the load. To maximize the overall efficiency an Active Clamp Technology are used in the rectifier side (secondary of the transformer). An active snubber, which consists of an active switch (MOSFET) and a capacitor, has to switch at twice the switching frequency and at the full power of the main dc/dc converter. This Active Clamp Technology will reduce the duty cycle losses. It reduces the number of switches, the gate drivers, and PWM channels significantly, which greatly simplifies the circuit structure. All power switches sustain only half of the input voltage. The output filter inductance is significantly reduced. The current stress of the switches is reduced due to the three-phase configuration. Active clamp circuit will store the losses and make use of it, by which the efficiency is improved. The losses are stored in the output filter capacitance

### 3. Simulation Diagram

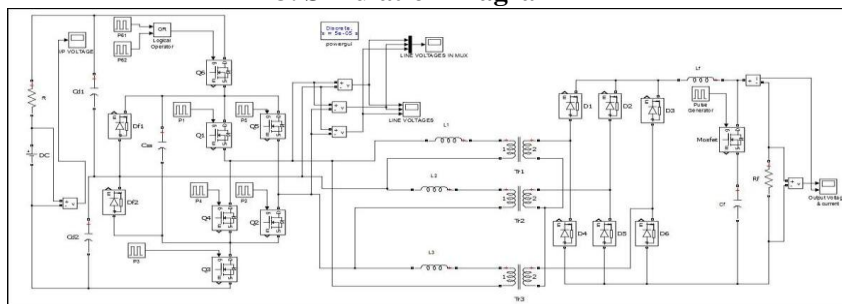

Figure 2: Simulation Diagram of TPTL DC/DC converter

The above diagram shows the simulation diagram of the three phase three level DC/DC converter

### 3.1. Line Voltage

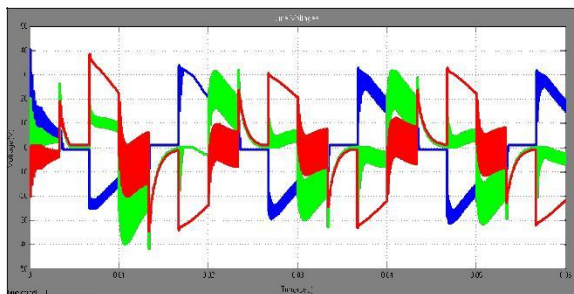

Figure 3: Simulated Inverter Line Voltage Diagram

### 3.2. Input Voltage

A 48V DC source is given to a three phase three level inverter, which is converted into AC. All power switches sustain only half of the input voltage due to the inverter configurations. Where  $V_{in} = 48\text{ V}$ , switching frequency  $f_s = 50\text{ kHz}$ . And the AC voltage is passed through the three phase transformer. The three-phase transformer with -Y connection is employed for the smaller turn's ratios and transformer VA rating. The input results are verified using MATLAB simulation, which is given in the Fig.2

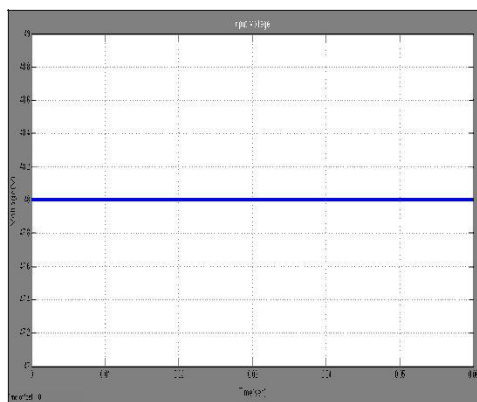

Figure 4: The simulated input voltage

### 3.3. Output Voltage and Output Current

The output of the 3 phase transformers is given to the three phase rectifier. In three phase rectifier the AC is converted to DC and they are given to the load. Where the output voltage  $V_o = 400\text{ V}$ , output current  $I_o = 3.5\text{ A}$ . The active clamp switch is placed in series with the output capacitance filter. The losses occurred in this processes is stored in the capacitance filter and it is used for the load, so that the overall efficiency can be improved. The output results are verified using MATLAB simulation, which is given in the Fig.3

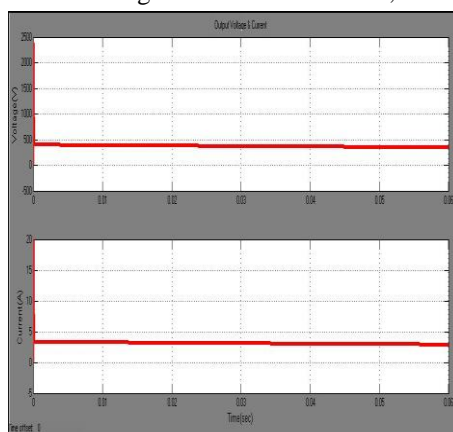

Figure 5: The simulated output voltage and current

#### 4. Conclusion

This paper proposed a novel TPTL dc/dc converter, which has the following characteristics. The converter can reduce the number of switches, the gate drivers, and PWM channels significantly, which greatly simplifies the circuit structure. All power switches sustain only half of the input voltage. The output filter inductance is significantly reduced due to the dramatic increase of output current ripple frequency. The current stress of the switches is reduced due to the three-phase configuration. The switches are hard-switching, which may cause considerable switching loss and low efficiency, by using active clamp switches the efficiency can be improved by storing the losses in the output capacitance filter and it is made used for the load . The converter has a voltage-fed characteristic at the input side, which will lead to a high input current ripple.

#### 5. References

- [1]. Sunil, G. E. Michael, and J. W. Michael, "Analysis and design of a new three-phase LCC-type resonant DC-DC converter with capacitor output filter," in Proc. IEEE Power Electron. Spec. Conf., 2000, pp. 721–728.
- [2]. M. Almardy and A. K. S. Bhat, "Three-phase (LC)(L)-type series resonant converter with capacitive output filter," in Proc. IEEE Int. Conf. Power Electron. Drive Syst., 2007, pp. 468–475.
- [3]. M. Almardy and A. K. S. Bhat, "Three-phase (LC)(L)-type series resonant converter: Design and experimental results," in Proc. Int. Conf. Electron. Devices, Syst. Appl., 2010, pp. 70–75.
- [4]. D. S. Oliveira and I. Barbi, "A three-phase ZVS PWM DC/DC converter with symmetrical duty cycle for high power applications," IEEE Trans. Power Electron., vol. 20, no. 2, pp. 370–377, Mar. 2005.
- [5]. D. S. Oliveira, Jr. and I. Barbi, "A three-phase ZVS PWM DC/DC converter with asymmetrical duty cycle associated with a three-phase version of the hybrid rectifier," IEEE Trans. Power Electron., vol. 20, no. 2, pp. 354–360, Mar. 2005.
- [6]. J. R. Pinheiro and I. Barbi, "The three-level ZVS-PWM DC-to-DC converter," IEEE Trans. Power Electron., vol. 8, no. 4, pp. 486–492, Oct. 1993.
- [7]. X. Ruan, L. Zhou, and Y. Yan, "Soft-switching PWM three-level converters," IEEE Trans. Power Electron., vol. 16, no. 5, pp. 612–622, Sep. 2001.
- [8]. T. Song, N. Huang, and A. Ioinovici, "Zero-voltage and zero-current switching three-level DC–DC converter with reduced rectifier voltage stress and soft-switching-oriented optimized design," IEEE Trans. Power Electron., vol. 21, no. 5, pp. 1204–1212, Sep. 2006.
- [9]. J. A. Carr, B. Rowden, and J. C. Balda, "A three-level full-bridge zero-voltage zero-current switching converter with a simplified switching scheme," IEEE Trans. Power Electron., vol. 24, no. 2, pp. 329–338, Feb. 2009.
- [10]. H. Cha and P. Enjeti, "A novel three-phase high power current-fed DC/DC converter with active clamp for fuel cells," in Proc. IEEE Power Electron. Spec. Conf., 2007, pp. 2485–2489.
- [11]. D. M. Sable and F. C. Lee, "The operation of a full-bridge, zero-voltage switched PWM converter," in Proc. Virginia Power Electron. Center Semin., 1989, pp. 92–97.
- [12]. X. Ruan and Y. Yan, "Soft-switching techniques for PWM full bridge converters," in Proc. IEEE Power Electron. Spec. Conf., 2000, pp. 634–639.
- [13]. P. D. Ziogas, A. R. Prasad, and S. Manias, "Analysis and design of a three phase off-line DC/DC converter with high frequency isolation," in Proc. IEEE Ind. Appl. Soc. Annu. Meeting, 1988, pp. 813–820.
- [14]. R. W. De Doncker, D. M. Divan, and M. H. Kheraluwala, "A three phase soft-switched high-power-density DC/DC converter for high-power applications," IEEE Trans. Ind. Appl., vol. 27, no. 1, pp. 63–73, Jan./Feb. 1991.
- [15]. J. Jacobs, A. Averberg, and R. De Doncker, "A novel three-phase DC/DC converter for high-power applications," in Proc. IEEE Power Electron. Spec. Conf., 2004, pp. 1861–1867