

Power Quality Enhancement of Distributed Network fed with Renewable Energy Sources based on Interfacing Inverter

A.VISHNUVARDAN¹, K.SUBBARAMAIAH²

¹PG student, Department of Electrical & Electronics Engineering,
YITS, TIRUPATHI

² professor, Department of Electrical & Electronics Engineering,
YITS, TIRUPATHI

Abstract: Renewable energy technologies such as photo voltaics, solar thermal electricity using dish-stirling systems, and wind turbine power are environmentally advantageous sources of energy that can be considered for electric power generation. The expenses of renewable energy technologies have decreased in recent years, so that an ever-increasing number of applications can be economically justified by utilities. The integration of generation from renewable energy sources into electric power distribution systems is a reasonable way for electric utilities to apply renewable energy resources, since it places the sources near the load with more efficient operation. The interfacing inverter is controlled to perform as a multi-function device by incorporating active power filter functionality and this inverter is used to inject power generated from Renewable Energy Sources to the grid. The objectives of this paper is to develop an assessment methodology for renewable energy electric generation and energy storage facilities integrated into electric power distribution systems which addresses the distributed benefits of electricity generation from renewable sources and their true value to the system, and to apply the methodology in case studies. The renewable energy sources which are interconnected to distributed network with interfacing power electronic inverter is analyzed for power quality enhancement by using MATLAB/SIMULINK software.

Index Terms: Renewable Energy Sources (RES), interfacing inverter, Power Quality, Active power filter.

I. INTRODUCTION

Renewable energy systems such as PV, solar thermal electricity such as dish-stirling systems, and WT are appropriate solar and wind technologies that can be considered for electric power generation at the distribution system level. Other renewable energy technologies, such as the solar central receiver, hydro-electric generation, geothermal, and large wind farms are normally connected to the grid at the sub-transmission or transmission level because of the higher power capacities of these types of systems. Presently, PV and WT technologies appear to be the most viable candidates for integration into power distribution systems as presented in .

The wind power development in the country is largely of recent period which has been found to be quite impressive. At present India is fifth in the world after Germany, USA, Denmark and Spain in terms of wind power. It has been observed that the private sector is showing interest in setting of wind power projects. The energy contained in the wind resource is more difficult to quantify on a national scale because its characteristics can change significantly from location to location and with height above the ground.

The wind energy collected by a wind turbine depends on many different factors, including the blade airfoil design and construction, the mechanical linkage design, the electric generator design, and the effects of the local terrain near the generator. With the advancement in power electronics and digital control technology, the DG systems can now be actively controlled to enhance the system operation with improved PQ at PCC. However, the extensive use of power electronics based equipment and non-linear loads at PCC generate harmonic currents, which may deteriorate the quality of power. Generally, current controlled voltage source inverters are used to interface the intermittent RES in distributed system. Recently, a few control strategies for grid connected inverters incorporating PQ solution have been proposed. In an inverter operates as active inductor at a certain frequency to absorb the harmonic current. A similar approach in which a shunt active filter acts as active conductance to damp out the harmonics in distribution network is proposed. In order to compensate for reactive power and higher harmonic components or to improve power factor, the active power (P) and reactive power (Q) should be controlled independently .

Moreover, the above system needs over-dimensioning some parts of the power converter in order to produce reactive power by the converter at rated active power by means of interfacing inverter. Here, the main idea is the maximum utilization of inverter rating which is most of the time underutilized due to intermittent nature of RES. It is shown in this paper that the grid-interfacing inverter can effectively be utilized to perform following important functions: 1) transfer of active power harvested from the renewable resources (wind, solar,

etc.); 2) load reactive power demand support; 3) current harmonics compensation at PCC; and 4) current unbalance and neutral current compensation in case of 3-phase 4-wire system.

II. INTERFACING INVERTER AND CONTROL

Basically each DG unit may have DC type or rectified generation unit which may be Fuel cell, solar cell, wind turbine, micro turbine, storage devices, DC-DC converter, DC-AC inverter, filter, and transformer for connecting to loads or utility in order to exchange power. Model and dynamic of each of this part may have influence in system operation. But here for simplification it is considered that DC side of the units has sufficient storage and considered as a constant DC source. Hence only DC-AC inverter modeling and control investigated in this paper. A circuit model of a three-phase DC to AC inverter with LC output filter is further described in Fig 1. The system consists of a DC voltage source (V_{dc}), a three-phase PWM inverter, an output filter (L_f and C with considering parasitic resistance of filter- R_f). Sometimes a transformer may be used for stepping up the output voltage and hence L_f can be transformer inductance. The carrier-based PWM technique fulfills such a requirement as it defines the on and off states of the switches of one leg of a VSI by comparing a modulating signal V_c (desired ac output voltage) and a triangular waveform V_D (carrier signal). In practice, when $V_c > V_D$ the switch S_1 is on and the switch S_2 is off; similarly, when $V_c < V_D$ the switch S_1 is off and the switch S_2 is ON. The PWM technique allows an ac output voltage to be generated that tracks a given modulating signal.

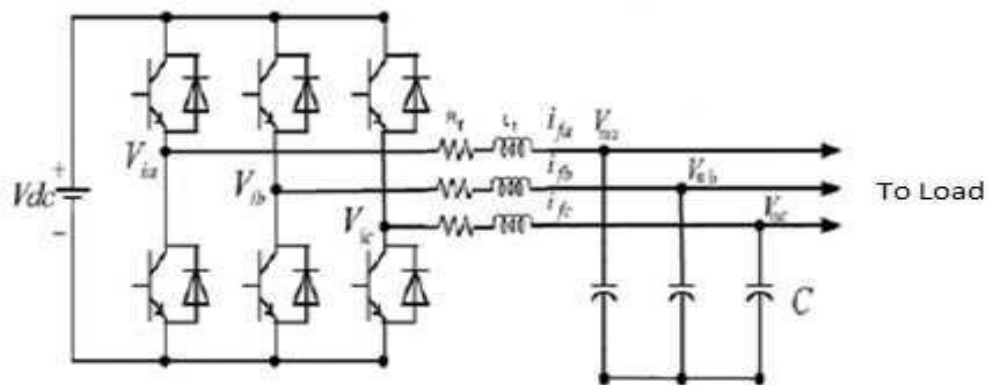

Fig 1. PWM interfacing inverter

A special case is the SPWM technique (the modulating signal is a sinusoidal) that provides in the linear region an ac output voltage that varies linearly as a function of the modulation index and the harmonics are at well-defined frequencies and amplitudes. These features simplify the design of filtering components.

III. ACTIVE POWER FILTERS

The active filters are commonly used for providing harmonic compensation to a system by controlling current harmonics in supply networks at the low to medium voltage distribution level or for reactive power or voltage control at high voltage distribution level. These functions may be combined in a single circuit to achieve the various functions mentioned above or in separate active filters which can attack each aspect individually. The block diagram presented in section shows the basic sequence of operation for the active filter is shown in Fig 2. The shunt active filters are by far the most widely accept and dominant filter of choice in most industrial processes.

The objective of the shunt active filter is to supply opposing harmonic current to the nonlinear load effectively resulting in a net harmonic current.

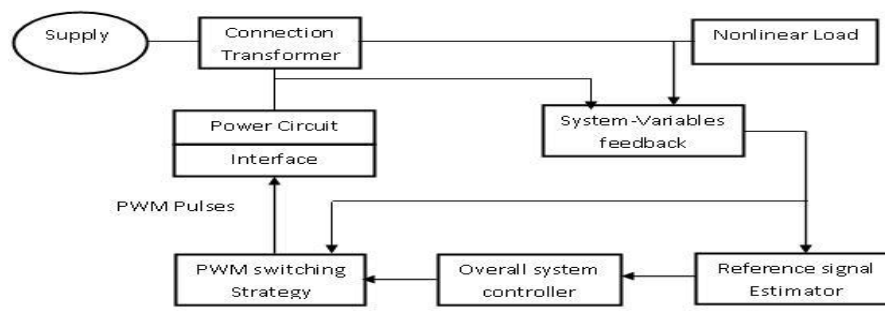

Fig 2. Block diagram of active power filter operation

The objective of the series active filter is to maintain a pure sinusoidal voltage waveform across the load. This is achieved by producing a PWM voltage waveform which is added or subtracted against the supply voltage waveform. The choice of power circuit used in most cases is the voltage-fed PWM inverter without a current minor loop. The active filter acts as a voltage source and thus it is often a preferred solution of harmonic producing loads such as large capacity diode rectifiers with capacitive loads. This diagram shows various sections of the filter each responding to its own classification. The block diagram shown in figure represents the key components of a typical active power filter along with their interconnections. The reference signal estimator monitors the harmonic current from the nonlinear load along with information about other system variables. The reference signal from the current estimator, as well as other signals, drives the overall system controller. This in turn provides the control for the PWM switching pattern generator. The output of the PWM pattern generator controls the power circuit through a suitable interface. The power circuit in the generalized block diagram can be connected in parallel, series or parallel/series configurations, depending on the transformer used.

IV. SYSTEM DESCRIPTION AND MODELLING OF CASE STUDY

The block diagram of proposed Renewable Energy Sources based distributed generation system connected to the dc-link of a grid-interfacing inverter is shown with interfacing inverter in Fig 3. The voltage source inverter is a key element of a DG system as it interfaces the renewable energy source to the grid and delivers the generated power. The RES may be a DC source or an AC source with rectifier coupled to dc-link. Usually, the fuel cell and photovoltaic energy sources generate power at variable low dc voltage, while the variable speed wind turbines generate power at variable ac voltage. Thus, the power generated from these renewable sources needs power conditioning (i.e., dc/dc or ac/dc) before connecting on dc-link. The dc-capacitor decouples the RES from grid and also allows independent control of converters on either side of dc-link. Due to the intermittent nature of RES, the generated power is of variable nature.

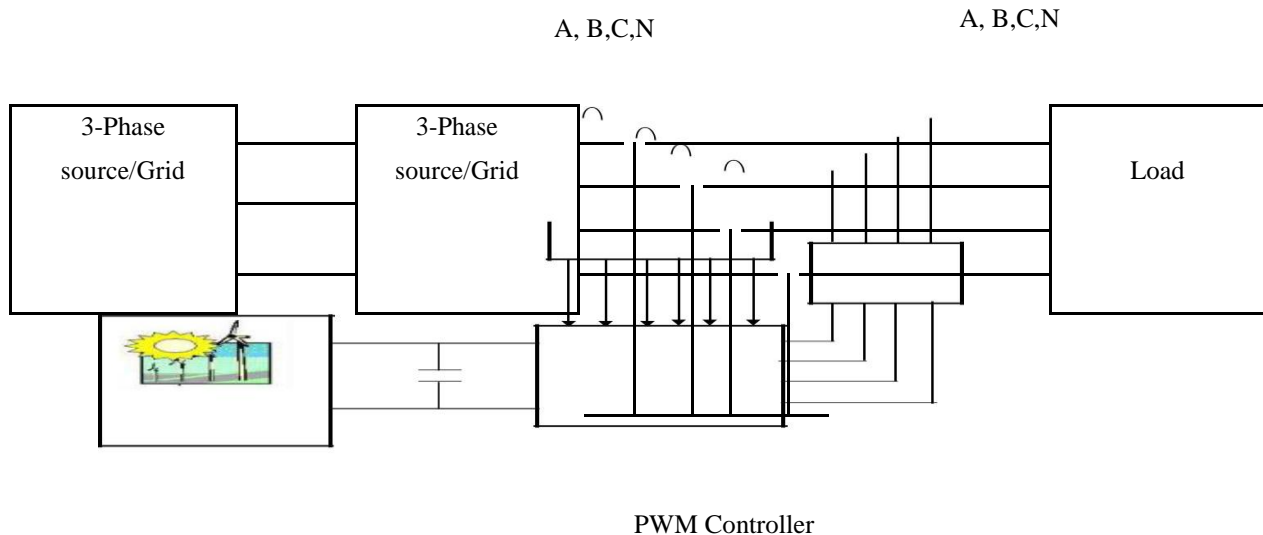

Fig 3. The proposed Block diagram of Renewable distributed inverter interfacing network

The dc-link plays an important role in transferring this variable power from renewable energy source to the grid. RES are represented as current sources connected to the dc-link of a grid-interfacing inverter. The fourth leg of inverter is used to compensate the neutral current of load. The duty ratio of inverter switches are varied in a power cycle such that the combination of load and inverter injected power appears as balanced resistive load to the grid. The regulation of dc-link voltage carries the information regarding the exchange of active power in between renewable source and grid. Thus the output of dc-link voltage regulator results in an active current. The multiplication of active current component with unity grid voltage components generates the reference grid currents for the controller. The reference grid neutral current is set to zero, being the instantaneous sum of balanced grid currents. While performing the power management operation, the inverter is actively controlled in such a way that it always draws/ supplies fundamental active power from/ to the grid. If the load connected to the PCC is neutral current of load.

V. SIMULATION RESULTS

In order to verify the proposed approach to achieve multi-objectives for grid interfaced inverter fed DG systems connected to a 3-phase 4-wire network, an extensive simulation study is carried out using

MATLAB/Simulink software package. A 4-leg current controlled voltage source inverter is keenly controlled to attain balanced sinusoidal grid currents at unity power factor (UPF) despite of highly unbalanced nonlinear load under varying renewable generating conditions. The waveforms of grid voltages, grid currents, unbalanced load current and inverter currents are shown in Fig.4 from which it is clear that the inverter interconnected grid system superior to that of a conventional environment. The corresponding active-reactive powers of grid, load and inverter are shown in Fig.5 to Fig.8. from these figures it is clear that, the Positive values of grid active-reactive powers and inverter active-reactive powers imply that these powers flow from grid side towards load and from inverter towards load respectively and has more reliable with the proposed method of interconnection of network through an inverter. When the power generated from renewable sources is more than the total power demand on the load, the grid-interfacing inverter with the proposed control approach not only satisfies the total load active and reactive power demand but also delivers the excess generated sinusoidal active power to the grid at nearly unity power factor.

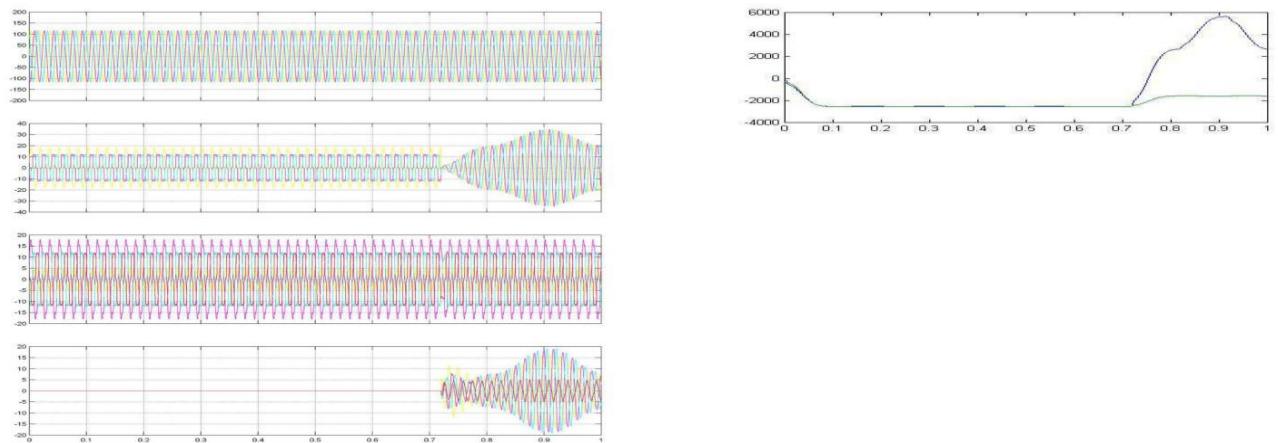

Fig 4. Simulation results: (a) Grid voltages, (b) Grid Currents (c) Unbalanced load currents, (d) Inverter Currents

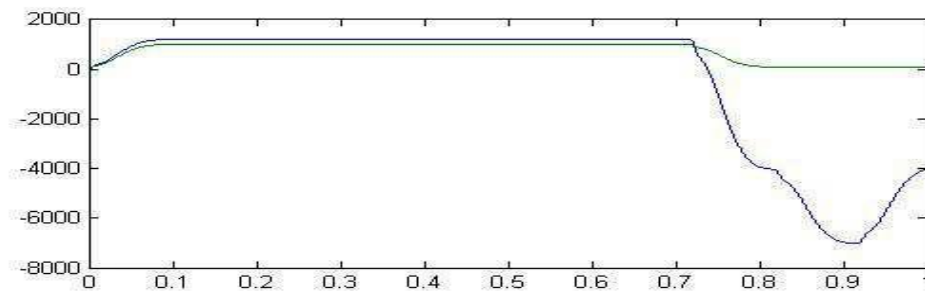

Fig 5. Simulation results of PQ-Grid

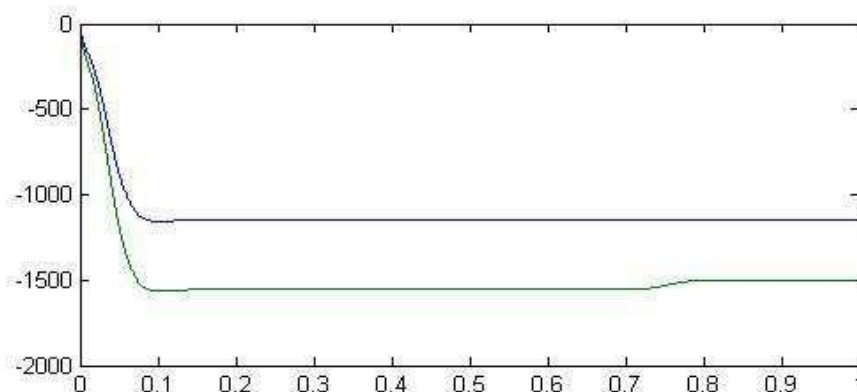

Fig 6. Simulation results of PQ-Inverter

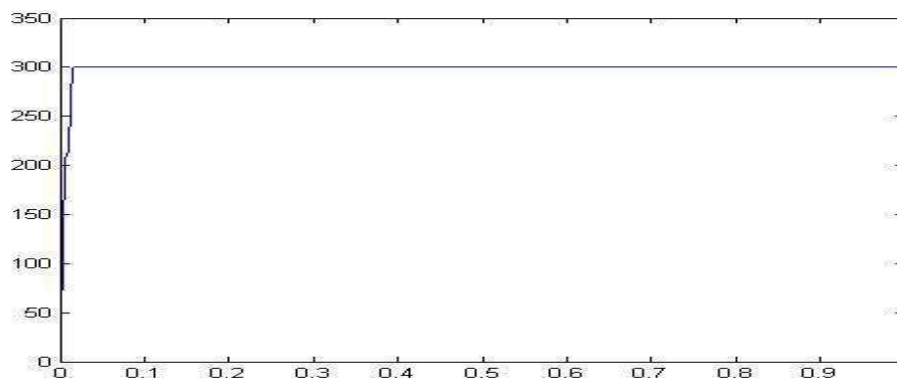

Fig 7. Simulation results of DC Voltage

VI. CONCLUSION

This simulation results presented is a novel control of an existing grid interfacing inverter to enhance the power quality at the load end for a 3-phase 4-wire DG system. It has been shown that the grid-interfacing inverter can be successfully utilized for power conditioning without affecting its normal operation of real power transfer to the load circuit. the simulation results concludes that the grid connected Renewable energy system can be used to send the real power from non conventional source end to the grid and it also operate as active power filter with fast response, high accuracy of tracking the DC-voltage reference, and strong robustness to unexpected load variations

REFERENCES

- [1] D. S. Shugar, "Photovoltaics in the Utility Distribution System: The Evaluation of System and Distribution Benefits," IEEE Trans. on Power Apparatus and Systems, Paper No. 0160-8371/90/0000-0836, 1990.
- [2] A.Ananda Kumar, J.Srinivasa Rao "Power Quality Improvement of Grid Interconnected 3-phase 4-wire Distribution System using Fuzzy logic control" "International Journal of Engineering Research & Technology (IJERT), Vol. 1 Issue 4, June - 2012 .
- [3] Yongning Chi, Yanhua Liu, Weisheng Wang, "Voltage Stability Analysis of Wind Farm integration into Transmission Network" IEEE Trans. Energy Conversion, vol. 21, issue 1, pp. 257-264, March. 2006
- [4] J. M. Guerrero, L. G. de Vicuna, J. Matas, M. Castilla, and J. Miret, "A wireless controller to enhance dynamic performance of parallel inverters in distributed generation systems," IEEE Trans. Power Electron., vol. 19, no. 5, pp. 1205-1213, Sep. 2004.
- [5] Bhim Singh, Kamal Al-Haddad, *Senior Member, IEEE*, and Amrith Chandra, *Member, IEEE* "A Review of Active Filters for Power Quality Improvement", *IEEE Trans. Ind. Elec-tron.*, vol. 46, no. 5, Sep. 1999.
- [6] R. Karki and P. Hu, "Wind power simulation model for reliability evaluation," in Electrical and Computer Engineering , 2005. Canadian Conference on, Los Alamitos, CA, 2005, pp. 541-544.
- [7] P. Jintakosonwitt, H. Fujita, H. Akagi, and S. Ogasawara, "Implementation and performance of cooperative control of shunt active filters for harmonic damping throughout a power distribution system," IEEE Trans. Ind. Appl., vol. 39, no. 2, pp. 556-564, Mar./Apr. 2003.
- [8] U. Borup, F. Blaabjerg, and P. N. Enjeti, "Sharing of nonlinear load in parallel-connected three-phase converters," IEEE Trans. Ind. Appl., vol. 37, no. 6, pp. 1817-1823, Nov./Dec. 2001.

Biographies



K.Subbaramaiah completed his graduation in the year 1996 and obtained his masters in the year 2001. At present he is pursuing his Ph.D at S.V.University. His research interests include power system operation and control,

fuzzy logic, deregulated market



A.vishnuvardan completed his graduation in the year 2012 in s.v.p.c.e.t puttur