

A Multilevel based dynamic voltage restorer- Ultra capacitor for improving power quality of distribution grid

K.V.Subbaramireddy¹, Mr. Krishna Deekshith²

¹(Jaepws student (Electrical), Svpct, India)

²(Jaepws Associate professor, Svpct, India)

ABSTRACT: In this project Cost of different energy storage technologies is diminishing quickly and the integration of these innovations into the power grid is turning into a reality with the approach of smart grid. Dynamic voltage restorer (DVR) is one item that can give enhanced voltage list and swell pay with energy storage integration. Ultra capacitors (UCAP) have low-energy density and high-control thickness perfect qualities for pay of voltage lists and voltage swells, which are both occasions that require high power for limited capacities to focus time. The novel commitment of this paper lies in the mix of rechargeable UCAP-based energy storage into the DVR topology.

KEYWORDS: DC-DC converter, d-q control, DSP, dynamic voltage restorer (DVR), energy storage integration, phase locked loop (PLL), sag/swell, Ultra capacitor (UCAP).

I. Introduction

The concept of utilizing inverter-based dynamic voltage restorers (DVRs) for keeping clients from transient voltage unsettling influences on the utility side was illustrated interestingly. The concept of utilizing the DVR as a power quality item has increased significant popularity since its first utilize. The creators propose the utilization of the DVR with rechargeable energy storage at the dc-terminal to meet the active power requirements of the grid during voltage unsettling influences. With a specific end goal to maintain a strategic distance from and minimize the dynamic power infusion into the grid, the creators additionally say an option arrangement which is to make up for the voltage sag by embeddings a lagging voltage in quadrature with the line current. Because of the high cost of rechargeable energy storage, different types of control techniques have additionally been created in the writing to minimize the dynamic force infusion from the DVR. The high cost of the rechargeable vitality stockpiling keeps the entrance of the DVR as a force quality item. In any case, the expense of rechargeable energy storage has been diminishing definitely in the later past because of different innovative advancements and because of higher entrance in the business sector as assistant energy storage for distributed energy resources (DERs, for example, wind, solar, hybrid electric vehicles (HEVs), and plug-in hybrid electric vehicle (PHEVs). Along these lines, there has been reestablished interest in the writing to coordinate rechargeable energy storage again at the dc-terminal of power quality items, for example, static compensator (STATCOM) and DVR.

Different sorts of rechargeable energy storage innovations in light of superconducting magnets (SMES), flywheels (FESS), batteries (BESS), and ultra capacitors (UCAPs) are looked for integration into advanced power applications such as DVR. Efforts have been made to coordinate vitality stockpiling into the DVR system, which will give the system active power capacity that makes it free of the matrix amid voltage disturbances. Fell H-span based DVR with a thyristor-controlled inductor is proposed to minimize the energy storage requirements.

Of all the rechargeable energy storage advancements, UCAPs are in a perfect world suited for applications which require active power support in the milliseconds to second's timescale. In this manner, UCAP-based incorporation into the DVR system is perfect, as the typical span of passing voltage droops and swells is in the milliseconds to second's range. UCAPs have low-vitality thickness and high-control thickness perfect attributes for remunerating voltage hangs and voltage swells, which are both occasions that require high measure of power for limited capacities to focus of time. UCAPs likewise have higher number of charge/release cycles when contrasted with batteries and for the same module size; UCAPs have higher terminal voltage when contrasted with batteries, which makes the coordination simpler. With the predominance of renewable energy sources on the distribution grid and the corresponding increase in power quality issues, the need for DVRs on the distribution grid is expanding.

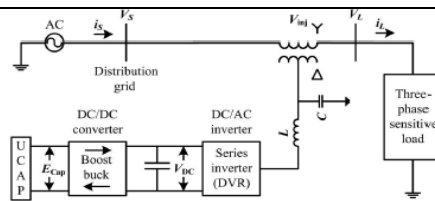

Fig.1. One-line diagram of DVR with UCAP energy storage.

Energy storage coordination to a DVR into the distribution grid is proposed and the following application areas are addressed.

- 1) Integration of the UCAP with DVR system gives active power capacity to the system, which is fundamental for independently compensating voltage sags and swells.
- 2) Experimental approval of the UCAP, dc–dc converter, what's more, inverter their interface and control.
- 3) Development of inverter and dc–dc converter controls to give sag and swell compensation to the distribution grid.
- 4) Hardware coordination and execution acceptance of the coordinated DVR-UCAP system.

II. Three phase series inverter

2.1. Power Stage

The one-line outline of the system is appeared in Fig. 1. The power stage is a three-phase voltage source inverter, which is associated in series to the grid and is responsible for compensating the voltage sags and swells; the model of the series DVR what's more, its controller is appeared in Fig. 2. The inverter system comprises of an insulated gate bipolar transistor (IGBT) module, its gate driver, LC channel, and a disengagement transformer. The dc-link voltage V_{dc} is directed at 260 V for ideal execution of the converter and the line–line voltage V_{ab} is 208 V; taking into account these, the modulation index m of the inverter is given by

$$m = \frac{2\sqrt{2}}{\sqrt{3}V_{dc} \cdot n} V_{ab(\text{rms})}. \quad (1)$$

Where n is the turn's proportion of the isolation transformer. Substituting n as 2.5 in (1), the required balance list is ascertained as 0.52. Accordingly, the output of the dc–dc converter should be directed at 260 V for giving precise voltage pay. The goal of the incorporated UCAPDVR system with active power capacity is to make up for impermanent voltage sag (0.1–0.9 p.u.) and voltage swell (1.1–1.2 p.u.), which last from 3 s to 1 min.

2.2. Controller Implementation

There are different strategies to control the series inverter to give dynamic voltage restoration and the greater part of them depend on infusing a voltage in quadrature with cutting edge stage, so that reactive power is used in voltage reclamation. Phase advanced voltage rebuilding systems are mind boggling in implementation, in any case, the essential purpose behind using these procedures is

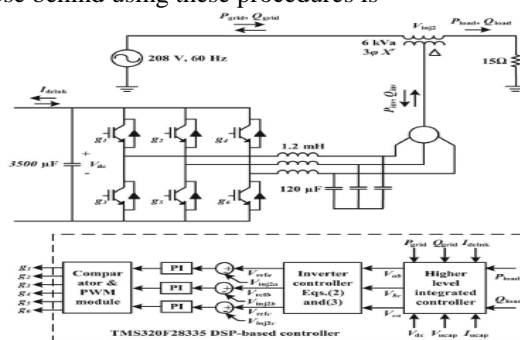

Fig.2. Model of three-phase series inverter (DVR) and its controller with integrated higher order controller.

To minimize the active power support and in this way the measure of energy storage requirement at the dc-link, so as to minimize the expense of energy storage. Nonetheless, the expense of energy storage has been

declining and with the availability of active power support at the dc-link, complicated phase propelled procedures can be stayed away from and voltages can be injected in-phase with the system voltage during a voltage sag or a swell occasion. The control strategy requires the utilization of a PLL to discover the rotating angle. As talked about beforehand, the objective of this anticipate is to utilize the active power ability of the UCAP-DVR system and adjust temporary voltage sag and swells.

The inverter controller execution depends on injected voltages in-phase with the supply-side line-neutral voltages. This requires PLL for evaluating θ , which has been executed utilizing the imaginary power technique portrayed. Taking into account the assessed θ and the line-line source voltages, V_{ab} , V_{bc} , and V_{ca} (which are accessible for this delta-sourced system) are changed into the d-q area and the line-impartial segments of the source voltage V_{sa} , V_{sb} , and V_{sc} , which are not accessible, can then be estimated using

$$\begin{bmatrix} V_{sa} \\ V_{sb} \\ V_{sc} \end{bmatrix} = \begin{bmatrix} 1 & 0 \\ -\frac{1}{2} & \frac{\sqrt{3}}{2} \\ -\frac{1}{2} & -\frac{\sqrt{3}}{2} \end{bmatrix} \begin{bmatrix} \cos(\theta - \frac{\pi}{6}) & \sin(\theta - \frac{\pi}{6}) \\ -\sin(\theta - \frac{\pi}{6}) & \cos(\theta - \frac{\pi}{6}) \end{bmatrix} \begin{bmatrix} \frac{V_d}{\sqrt{3}} \\ \frac{V_q}{\sqrt{3}} \end{bmatrix} \quad (2)$$

$$\begin{bmatrix} V_{refa} \\ V_{refb} \\ V_{refc} \end{bmatrix} = m * \begin{bmatrix} (\sin \theta - \frac{V_{sa}}{169.7}) \\ (\sin(\theta - \frac{2\pi}{3}) - \frac{V_{sb}}{169.7}) \\ (\sin(\theta + \frac{2\pi}{3}) - \frac{V_{sc}}{169.7}) \end{bmatrix} \quad (3)$$

$$P_{inv} = 3V_{inj2a(rms)}I_{La(rms)} \cos \varphi$$

$$Q_{inv} = 3V_{inj2a(rms)}I_{La(rms)} \sin \varphi. \quad (4)$$

These voltages are standardized to unit sine waves utilizing line-neutral system voltage of 120Vrms as reference and looked at to unit sine waves in-stage with real system voltages V_s from (3) to discover the infused voltage references V_{ref} fundamental to keep up a consistent voltage at the load terminals, where m is 0.52 from (1). In this way, at whatever point there is a voltage sag on the other sag swell on the source side, a comparing voltage V_{inj2} is injected in-stage by the DVR and UCAP system to discredit the impact and hold a consistent voltage V_L at the loads end. The real active and reactive power supplied by the arrangement inverter can be processed utilizing (4) from the rms estimations of the infused voltage V_{inj2a} and load current I_{La} , and φ is the phase distinction between the two waveforms.

III. UCAP and Bidirectional DC-DC Converter

3.1. UCAP Bank Hardware Setup

The decision of the quantity of UCAPs fundamental for giving grid support relies on upon the measure of bolster required, terminal voltage of the UCAP, dc-link voltage, and circulation network voltages. In this paper, the trial setup comprises of three 48 V, 165F UCAPs (BMOD0165P048) fabricated by Maxwell Technologies, which are associated in arrangement. In this manner, the terminal voltage of the UCAP bank is 144 V and the dc-link voltage is modified to 260 V. This would give the dc-dc converter a practical operating duty ratio of 0.44–0.72 in the help mode while the UCAP is releasing and 0.27–0.55 in the buck mode while the UCAP is charging from the grid through the dc-link and the dc-dc converter. It is reasonable also, cost-effective to utilize three modules in the UCAP bank. Accepting that the UCAP bank can be released to half of its underlying voltage ($V_{uc,ini}$) to definite voltage ($V_{uc,fin}$) from 144 to 72 V, which means profundity of release of 75%, the vitality in the UCAP bank accessible for discharge is given by

$$E_{UCAP} = \frac{1}{2} * C * \frac{(V_{uc,ini}^2 - V_{uc,fin}^2)}{60} W - \min$$

$$E_{UCAP} = 1/2 * 165 / 3 * (144^2 - 72^2) / 60 \quad (5)$$

$$= 7128 W - \min.$$

3.2. Bidirectional DC-DC Converter and Controller

A UCAP can't be straightforwardly associated with the dc-connection of the inverter like a battery, as the voltage profile of the UCAP changes as it releases energy. Along these lines, there is a need to incorporate the UCAP system through a bidirectional dc-dc converter, which keeps up a firm dc-link voltage, as the UCAP voltage diminishes while releasing and increments while charging. The model of the bidirectional dc-dc converter and its controller are appeared in Fig. 3, where the information comprises of three UCAPs associated in arrangement and the output comprises of an ostensible burden of 213.5 Ω to counteract operation at no-heap, and the output is associated with the dc-connection of the inverter. The measure of dynamic power support required by the system amid a voltage droop occasion is reliant on the profundity and length of the voltage hang, and the dc-dc converter ought to have the capacity to withstand this power during the release mode. The dc-dc converter ought to likewise be capable

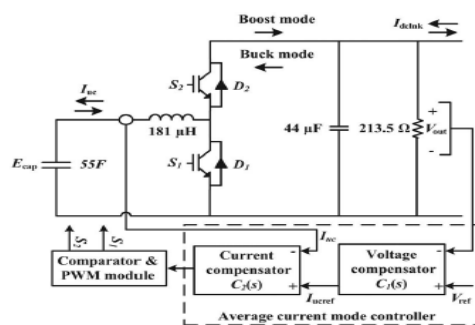

Fig.3. Model of the bidirectional dc–dc converter and its controller.

To work in bidirectional mode to have the capacity to charge or absorb extra power from the grid during voltage swell occasion. In this paper, the bidirectional dc–dc converter goes about as a support converter while releasing power from the UCAP and goes about as a buck converter while charging the UCAP from the lattice.

A bidirectional dc–dc converter is required as an interface between the UCAP and the dc-link following the UCAP voltage changes with the measure of energy released while the dc-link voltage must be firm. Along these lines, the bidirectional dc–dc converter is intended to work in support mode when the UCAP bank voltage is somewhere around 72 and 144 V and the output voltage is directed at 260 V. At the point when the UCAP bank voltage is underneath 72 V, the bidirectional dc–dc converter is worked in buck mode and draws energy from the grid to charge the UCAPs and the yield voltage is again controlled at 260 V.

Normal current mode control, which is broadly investigated in writing, is utilized to manage the output voltage of the bidirectional dc–dc converter in both buck and help modes while charging and releasing the UCAP bank. This strategy tends to be steadier when contrasted with different strategies, for example, voltage mode control and crest current mode control. Normal current mode controller is appeared in Fig. 3, where the dc-link what's more, actual output voltage V_{out} is contrasted and the reference voltage V_{ref} and the error is gone through the voltage compensator $C_1(s)$, which creates the normal reference current I_{ucref} . When the inverter is releasing power into the grid during voltage list occasion, the dc-link voltage V_{out} has a tendency to go underneath the reference V_{ref} and the mistake is certain; I_{ucref} is sure and the dc–dc converter works in support mode. At the point when the inverter is retaining power from the grid during voltage swell occasion alternately charging the UCAP, V_{out} tends to increment over the reference V_{ref} and the blunder is negative; I_{ucref} is negative and the dc–dc converter works in buck mode. In this way, the indication of the error amongst V_{out} and V_{ref} decides the indication of I_{ucref} also, along these lines the heading of operation of the bidirectional dc–dc converter. The reference current I_{ucref} is then contrasted with the real UCAP current the compensator transfer functions, which provide a stable response, are given by

$$C_1(s) = 1.67 + \frac{23.81}{s} \quad (6)$$

$$C_2(s) = 3.15 + \frac{1000}{s} \quad (7)$$

Extension

IV. Multilevel inverter

Numerous industrial applications have begun to require higher power apparatus in recent years. Some medium voltage motor drives and utility applications require medium voltage and megawatt power level. For a medium voltage grid, it is troublesome to connect only one power semiconductor switch directly. As a result, a multilevel power converter structure has been introduced as an alternative in high power and medium voltage situations. A multilevel converter not only achieves high power ratings, but also enables the use of renewable energy sources. Renewable energy sources such as photovoltaic, wind, and fuel cells can be easily interfaced to a multilevel converter system for a high power application.

The term multilevel began with the three-level converter. Subsequently, several multilevel converter topologies have been developed. However, the elementary concept of a multilevel converter to achieve higher power is to use a series of power semiconductor switches with several lower voltage dc sources to perform the power conversion by synthesizing a staircase voltage waveform. Capacitors, batteries, and renewable energy voltage sources can be used as the multiple dc voltage sources. The commutation of the power switches aggregate these multiple dc sources in order to achieve high voltage at the output; however, the rated voltage of the power semiconductor switches depends only upon the rating of the dc voltage sources to which they are connected.

A multilevel converter has several advantages over a conventional two-level converter that uses high switching frequency pulse width modulation (PWM). The attractive features of a multilevel converter can be briefly summarized as follows. ●Staircase waveform quality: Multilevel converters not only can generate the output voltages with very low distortion, but also can reduce the dv/dt stresses; therefore electromagnetic compatibility (EMC) problems can be reduced.

● Common-mode (CM) voltage: Multilevel converters produce smaller CM voltage; therefore, the stress in the bearings of a motor connected to a multilevel motor drive can be reduced. Furthermore, CM voltage can be eliminated by using advanced modulation strategies such as that proposed.

● Input current: Multilevel converters can draw input current with low distortion.

●Switching frequency: Multilevel converters can operate at both fundamental switching frequency and high switching frequency PWM. It should be noted that lower switching frequency usually means lower switching loss and higher efficiency.

Unfortunately, multilevel converters do have some disadvantages. One particular disadvantage is the greater number of power semiconductor switches needed. Although lower voltage rated switches can be utilized in a multilevel converter, each switch requires a related gate drive circuit. This may cause the overall system to be more expensive and complex.

V. Simulation results

5.1. Sag

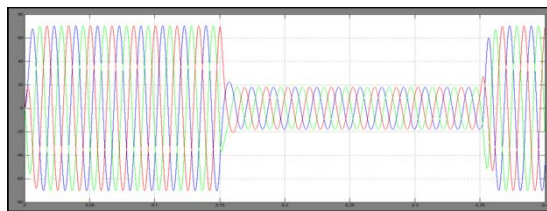

Fig.4. Source voltages V_{sab} (blue), V_{sbc} (red), and V_{sca} (green) during sag

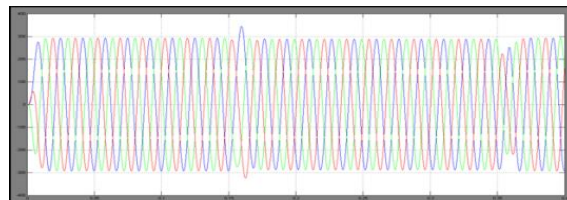

Fig.5. Load voltages V_{Lab} (blue), V_{Lbc} (red), and V_{Lca} (green) during sag

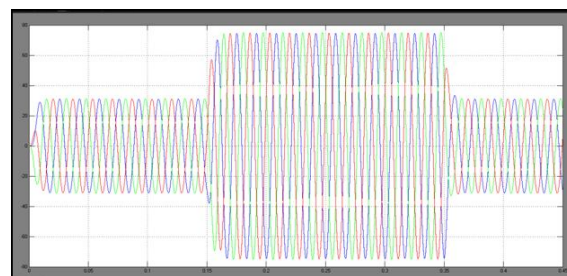

Fig.6. Injected voltages V_{inj2a} (blue), V_{inj2b} (red), and V_{inj2c} (green) during sag

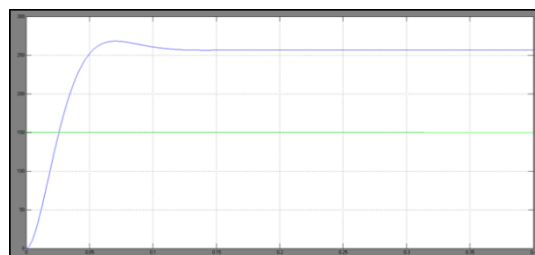

Fig.7. Source and load RMS voltages V_{srms} and V_{Lrms} during sag

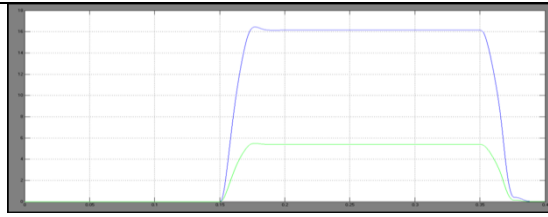

Fig.8. Voltages of dc–dc converter during voltage sag

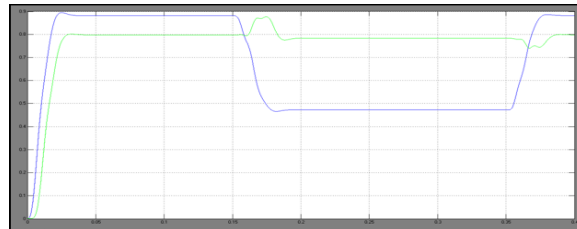

Fig.9. Currents of dc–dc converter during voltage sag

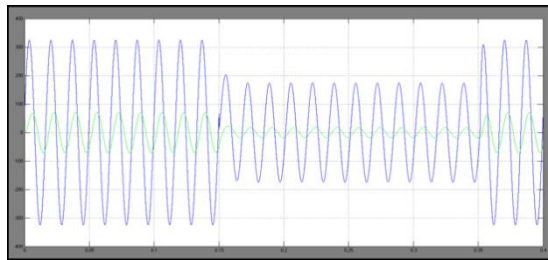

Fig.10. Vinj2a (green) and Vsab (blue) waveforms during sag

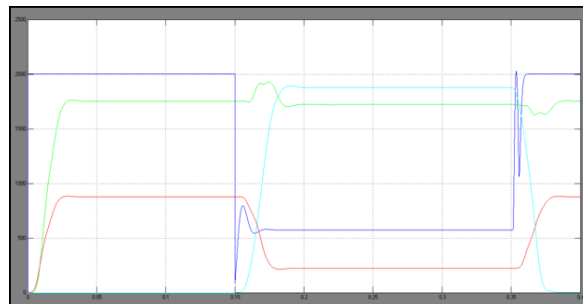

Fig.11. Active power of grid, Load and inverter during voltage sag

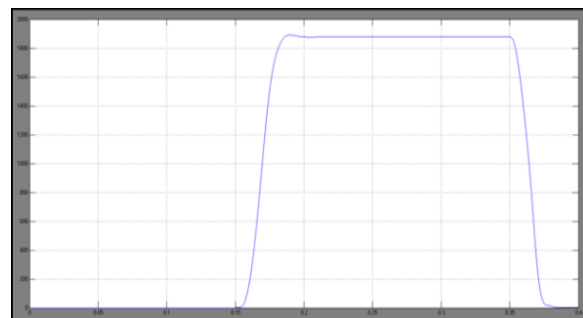

Fig.12. Voltages of dc–dc converter during voltage sag

5.2. Swell

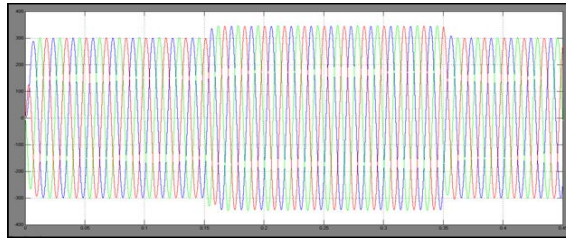

Fig.13. Source voltages V_{sab} (blue), V_{sbc} (red), and V_{sca} (green) during swell

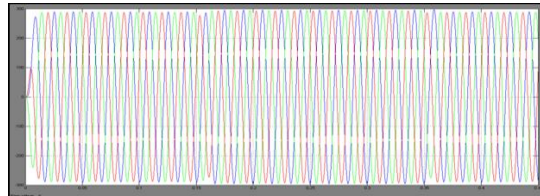

Fig.14. Load voltages V_{Lab} (blue), V_{Lbc} (red), and V_{Lca} (green) during swell

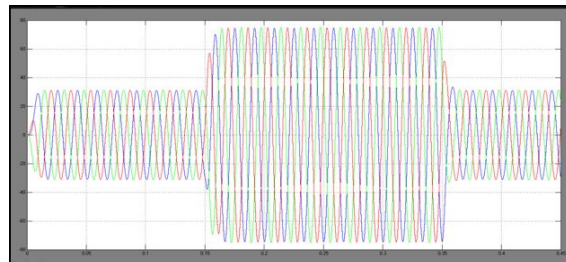

Fig.15. Injected voltages V_{inj2a} (blue), V_{inj2b} (red), and V_{inj2c} (green) during swell

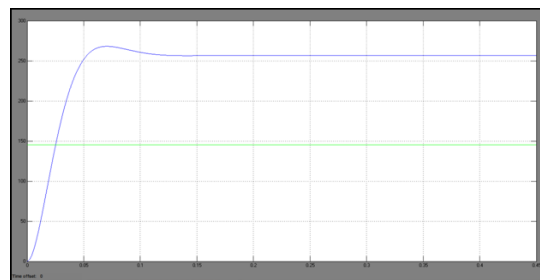

Fig.16. Voltages of dc-dc converter during voltage swell

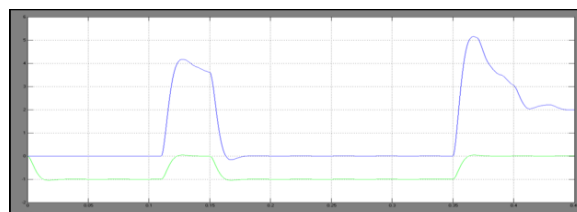

Fig.17. Currents of dc-dc converter during voltage swell

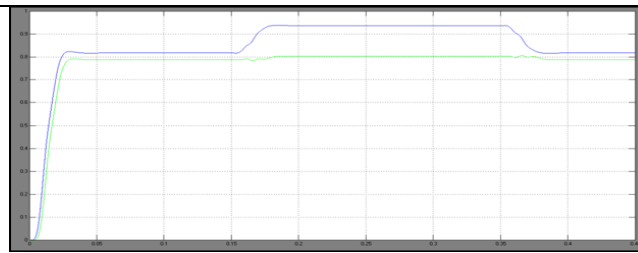

Fig.18. Active power of grid, Load and inverter during voltage swell The values for extestion and proposed

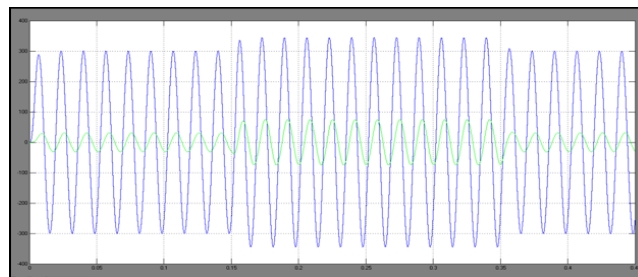

Fig.19. Vinj2a (green) and Vsab (blue) waveforms during swell

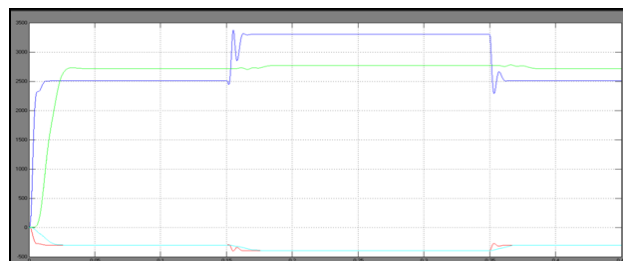

Fig.20. Active power of grid, Load and inverter during voltage swell The values for extestion and proposed

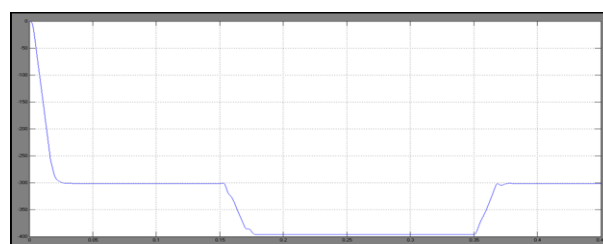

Fig.21. Voltages of dc-dc converter during voltage swell

5.3. The values for extestion and proposed

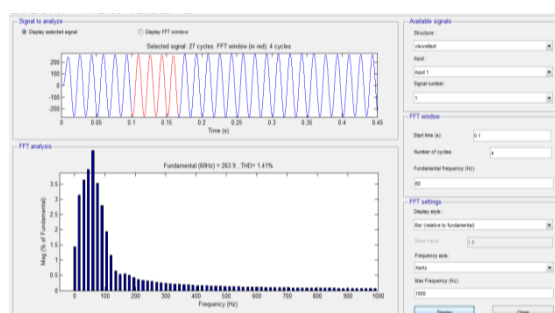

Fig.22. Sag ext 1.41%

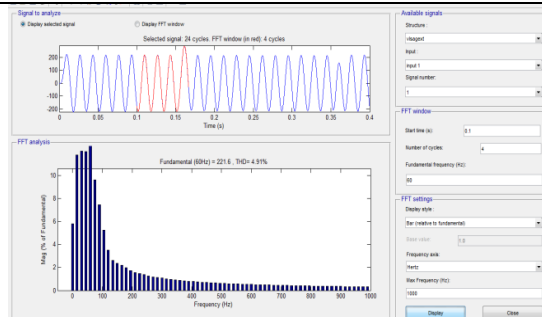

Fig.23. Swell ext 4.91%

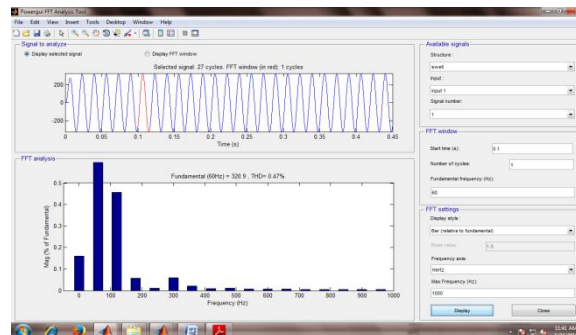

Fig.24. Sag proposed 0.32%

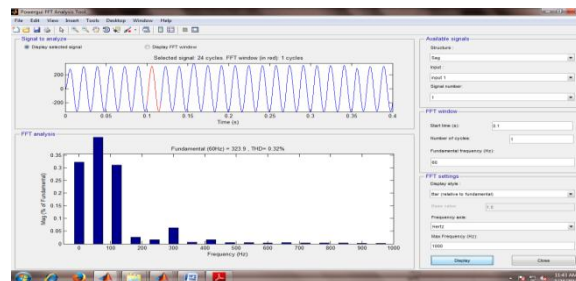

Fig.25. Swell proposed 0.45%

6. Conclusion

In this project the idea of integrating UCAP-based rechargeable energy storage to the DVR system to enhance its voltage reclamation capacities is investigated. With this joining, the DVR will have the capacity to freely repay voltage sags and swells without depending on the lattice to make up for shortcomings on the system. The UCAP coordination through a bidirectional dc–dc converter at the dc-connection of the DVR is proposed. The power stage and control technique of the series inverter, which goes about as the DVR, are talked about. The control system is straightforward what's more, depends on infusing voltages in-stage with the system voltage what's more, is less demanding to actualize when the DVR system has the capacity to give dynamic force. Plans of real parts in the power phase of the bidirectional dc–dc converter are talked about. Normal current mode control is utilized to direct the output voltage of the dc–dc converter because of its innately steady trademark. The recreation of the UCAP-DVR system, which comprises of the UCAP, dc–dc converter, and the matrix tied inverter, is completed utilizing PSCAD. Equipment trial setup of the incorporated framework is exhibited and the capacity to give impermanent voltage droops and swells.

References

- [1]. N. H. Woodley, L. Morgan, and A. Sundaram, "Experience with an inverter-based dynamic voltage restorer," *IEEE Trans. Power Del.*, vol. 14, no. 3, pp. 1181–1186, Jul. 1999.
- [2]. S. S. Choi, B. H. Li, and D.M. Vilathgamuwa, "Dynamic voltage restoration with minimum energy injection," *IEEE Trans. Power Syst.*, vol. 15, no. 1, pp. 51–57, Feb. 2000.
- [3]. D. M. Vilathgamuwa, A. A. D. R. Perera, and S. S. Choi, "Voltage sag compensation with energy optimized dynamic voltage restorer," *IEEE Trans. Power Del.*, vol. 18, no. 3, pp. 928–936, Jul. 2003.
- [4]. Y. W. Li, D. M. Vilathgamuwa, F. Blaabjerg, and P. C. Loh "A robust control scheme for medium-voltage-level DVR implementation," *IEEE Trans. Ind. Electron.*, vol. 54, no. 4, pp. 2249–2261, Aug. 2007.
- [5]. A. Ghosh and G. Ledwich, "Compensation of distribution system voltage using DVR," *IEEE Trans. Power Del.*, vol. 17, no. 4, pp. 1030–1036, Oct. 2002.