

## **Design and Construction of an Inverter Amplifier Circuit for a Mosquito Zapper**

<sup>1</sup>M. Alpha, <sup>2</sup>JUMMAI .D. Makama., <sup>3</sup>KURE .N., <sup>4</sup>BELLO .I. A, <sup>5</sup>T. O. DANIEL., <sup>6</sup>ISLAMIYAT .T. Salaudeen., <sup>7</sup>ADOYI Emmanuel,

*1&6Department of Physics, Federal University of Technology Minna, P.M.B 65,*

*5. Department of Physics/geophysics, federal University Ndufu-Alike, Ikwo, P.M.B 1010, Abakaliki, Nigeria*

*3. Department of Physics, kaduna state university*

*2&4 Department of Physics Ahmadu Bello University*

*7 Department of Physics, NDA Kaduna*

---

**Abstract:** This work entails the design and construction of a high voltage inverter amplifier circuit for mosquito zapper which can electrocute mosquitoes. It also consists of a power supply unit which is mainly used to charge the battery and the casing was done using Perspex plastic material. The mesh dimension is 33 cm by 23 cm and had one inner mesh with 2 outer ones.

**Key Words:** Zapper, Inverter, amplifier, Mosquito

---

### **I. Introduction**

A mosquito zapper is a device used for killing mosquitoes using high voltages, [3]. The power supply is either battery or rectified voltage source. The control device is a switch to operate the Zapper. Current is acceptable through a transistor which allows the current to flow through a primary coil, inducing voltage in the secondary coil and the secondary coil in return induces voltage in feedback coil. This counter voltage in the feedback coil causes the transistor to stop conducting and the magnetic field in the ferrite core to collapse via electrical energy from secondary coil.[2] This process helps the transistor to conduct again, repeating the process and creating pulsed DC. The changing magnetic field induces high voltage in the secondary coil. Voltage induced in the secondary coil depends on the ratio of number of turns of Primary and Secondary winding. This voltage will be in the order of a few hundreds or thousands.

This voltage is now further boosted using a mixture of Diodes and Capacitors, which is a voltage amplifier. Characteristically, the circuit uses Voltage Tripler, which triples the available voltage from secondary winding of transformer[1].

Out of 3 layers of the mesh, the outer two layers are connected to -Ve/GND and the inner layer connected to the generated high voltage. The distance between the meshes will not let the high voltage arc off on its own. But when mosquito/bug flies in between, it helps in formation of low resistance path, which results in arcing through the body of the mosquito, [4].

### **II. Materials and Methods**

#### **2.1: General Circuit Diagram and Its Operation Principle**

The main body resistance of most bugs and mosquitoes fall within the range of  $0.70 - 0.75\Omega$  and the required Zapper voltage is from 600 to 1200 volts ac. Figure 1.1 is the general circuit diagram of the Zapper. It was conceived from the many on the net to be shown having four simple sections as earlier stated above.

The Zapper Circuit functions by the following principles; when the battery power is switched on, the RC oscillator produces a waveform like a square wave which switches transistor T1 On and Off and as such allows the battery current to be switched to and from the centre tapped transformer which sees the voltage as an AC Voltage. This voltage is induced into the pulse transformer secondary winding through electromagnetic induction. And because the transformer is in step up mode, the voltage is increased by 100 times to give an output which when tripled produces the required voltage that can electrocute a bug or insect. The output of the Tripler is connected to 2 meshes whereby the inner mesh called the hot mesh carries the high voltage while the outer meshes carry a ground potential.

Fig. 1.1 General Zapper circuit diagram

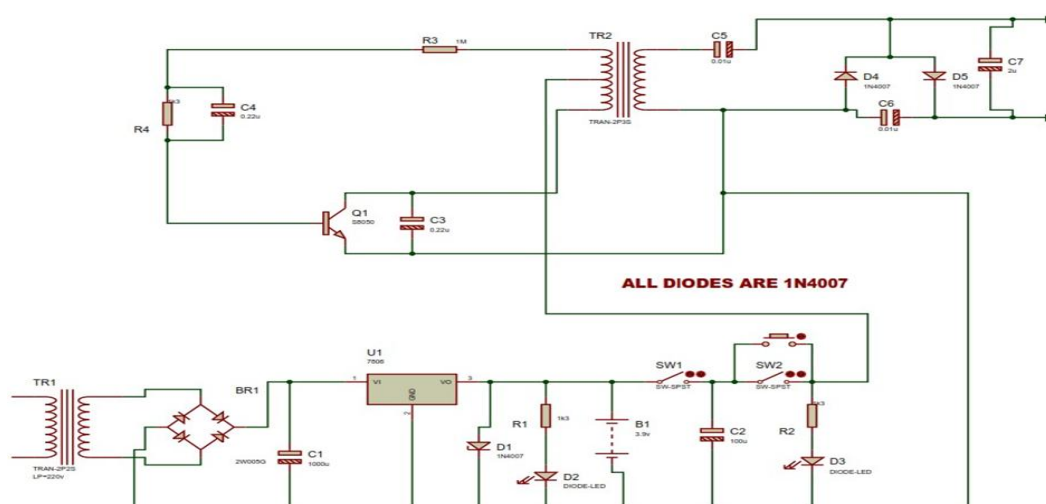

### The Oscillatory Stage Design

The RC oscillator was chosen to avoid the bulkiness of inductive circuits and its easy application to inverter circuits.

The RC tank used consists of a resistor and a capacitor as in Figure 1.2.

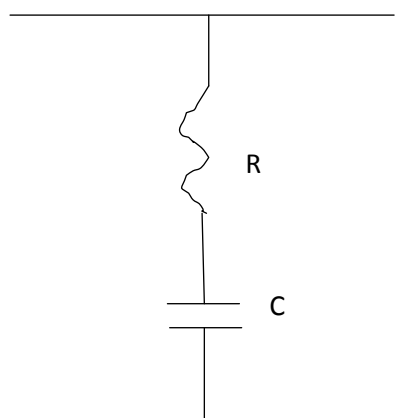

Figure 1.2 RC Oscillators

The time constant is  $\tau = RC$

For most Zapper oscillators the frequencies of 0 to 100 Hz are taken. Therefore a 1 M $\Omega$  resistor was chosen for 5Hz frequency, Clark (2003).

$$\tau = RC \tag{1.1}$$

$$= \frac{1}{2\pi fc} \tag{1.2}$$

$$fc = \frac{1}{2\pi RC} \tag{1.3}$$

So therefore if  $fc = 5$  Hz and  $R = 1M\Omega$  then

$$5 = \frac{1}{2\pi \times 1 \times 10^6 \times C}$$

$$C = \frac{1}{5 \times 10^6 \times 2\pi} = 20\mu f$$

After this test, the circuit was then connected beginning with the oscillator (RC) as shown in Figure 1.3. A test on the RC oscillator showed a low frequency distorted saw wave which is used to switch transistor T1 thereby driving the transformer with collector current  $I_c$

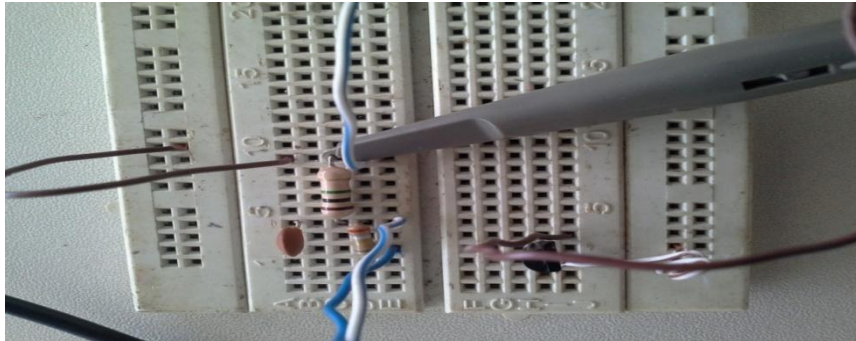

Figure 1.3 RC Oscillator Test

Other test carried out was with digital multi meter to obtain the voltage at the transformer output and around the circuit.

### Inverter Amplifier Design

The switching amplifier is a transistor switch which acts as an inverter power switch. The circuit of the transistor amplifies the output of the oscillator so as to switch power through the transformer as shown in Figure 1.4.

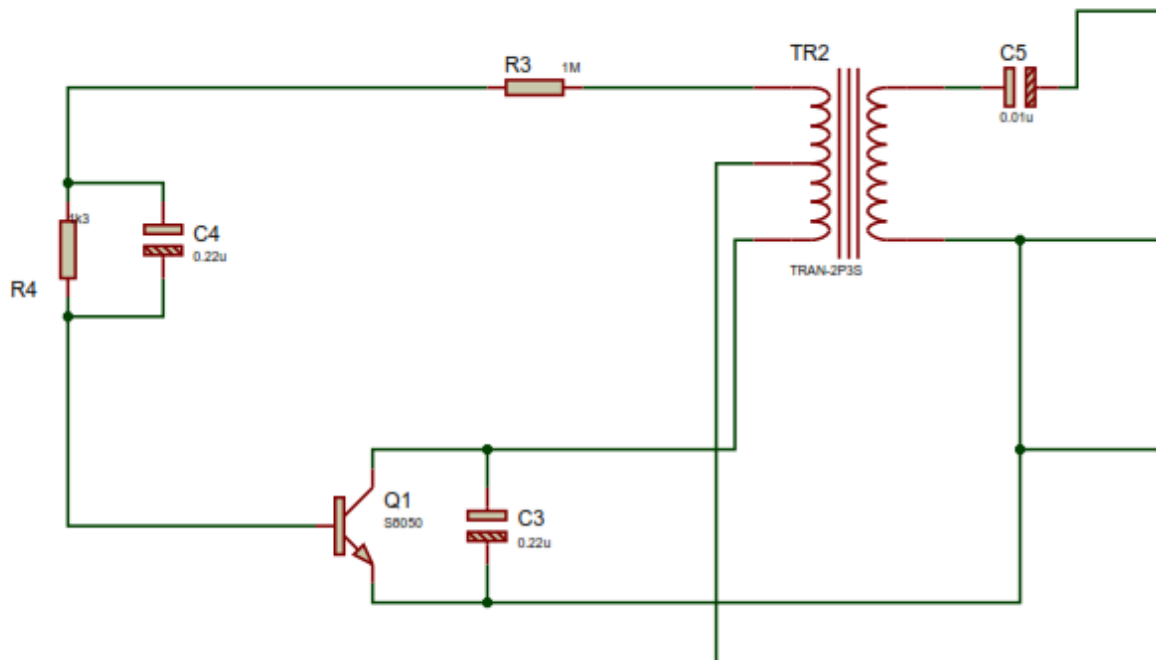

Figure 1.4 One Transistor Inverter amplifiers

The transformer was designed based on the earlier findings that 1000 V was required to zap a bug so there is a need to generate this voltage at the tripler output. But before this the voltage at the battery for the inverter is 3.9 V. If the transformer has an input of 3.9 V and requires to give an output of 330 V that when tripled will give the required 1000 V then the winding of the transformer can be designed for that reason. The idea of the transformer output was taken from the specified voltage level for killing a bug. If the voltage is 1000

V then that is what is expected at the output of the Tripler. The primary voltage is taken from a switched DC source is 3.9 V. The transistor was selected based on the battery current which was obtained from the specification as in table 1.1.

Table 1.1 Battery Specifications

V	3.9V
I	1020mAh
Is	30mA
Life expectancy	2973.761hours
Advanced Charging	6 V

The transistor was selected to be capable of handling battery current of 30 mA and from data sheet of the transistor a S8050 was chosen. Below is the data sheet of the transistor S8050 in Table 1.2.

Table 1.2 Absolute Maximum Ratings (Ta=25 C) S805

Rating	Symbol	Value	Unit
Collector-Emitter Voltage	V <sub>CEO</sub>	25	V dc
Collector-Base Voltage	V <sub>CB0</sub>	40	V dc
Emitter-Base Voltage	V <sub>EBO</sub>	5.0	V dc
Collector Current	I <sub>C</sub>	500	mA dc
Total Device Dissipation TA=25 C	P <sub>D</sub>	0.625	W
Junction Temperature	T <sub>j</sub>	150	C
Storage, Temperature	T <sub>stg</sub>	-55 to+150	C

Using a bread board the circuit was quickly assembled after winding the transformer and from a 3.9 V battery a 334.2 V was obtained at the transformer output. This voltage can now be tripled by the Tripler circuit to obtain the desired 1000 V required to zap bug or kill mosquito. An additional component R4 was added to the circuit after this experiment because it was found out that residual voltage in the capacitor prevented transistor from proper switching required by the inverter unit. Its value was taken as 4.7 KΩ to discharge the capacitor after every cycle.

### Measurement/Results

During the construction of this work some preliminary measurements were carried out on the components to be sure they are in good working conditions. Table 1.3 shows the component test.

Table 1.3 Component test

Component	Value	Meter Test	Value by colour code	Remark
Resistor	1MΩ	0.999 MΩ	1MΩ ± 5%	

### *Design and Construction of an Inverter Amplifier Circuit for a Mosquito Zapper*

Diodes	1N4007	0.585 $\Omega$		Pass current in one direction
Transistor	S8050	B→E→0.890		Good
		B→C→0.699		
		B→E→ open circuit		
		B→ C→ open circuit		
Transformer	TLB114	Low $\Omega = N_p$		Continuity
Capacitors	C104	Very high resistance		Considered open circuit

### **Conclusion**

In **Conclusion**, induce voltage in the secondary coil induces voltage in feedback coil. This counter voltage in the feedback coil causes the transistor to stop conducting and the magnetic field to collapse by means of electrical energy from secondary coil. This process helps the transistor to conduct again, repeating the process and creating pulsed dc. The changing magnetic field induces high voltage in the secondary coil. Voltage induced in the secondary coil depends on the ratio of number of turns of Primary and Secondary winding. The distance between the meshes will not let the high voltage arc off on its own. But when mosquito flies in between, it helps in formation of a low resistance pathway, which results in arcing through the body of the mosquito.

### **REFERENCES**

- [1]. Alvin D. Willbanks (2000) *Infrared Insect Mosquito Killing System*. Retrieved from [www.google.com/patents/US6050025](http://www.google.com/patents/US6050025)
- [2]. Christopher Buckley (2003) *History of the Bug Zapper*. Retrieved from <http://www.forbes.com/forbeslifemagazine2003/0526/088.html>
- [3]. F.Folmer and Harrison L.Chapin (1934) *Insect Exterminator*. Retrieved from <http://www.google.com/patents/US1962439>
- [4]. Zapper.(n.d.) *American Heritage® Dictionary of the English Language, Fifth Edition*.(2011). Retrieved from <http://www.thefreedictionary.com/zapper>