

An Active Type SFCL to Reduce the Fault Current and Over Voltage in A Distributed System with Distribution Generation Units

V.N.SARASWATHI¹, K.KALPANA²

M.Tech [PE&ED], PG Scholar, Dept. of EEE, Sri Venkatesa Perumal College of Engineering & Technology, Puttur, Andhra pradesh, India¹.

M.Tech[EPS], Assistant professor, Dept. of EEE, Sri Venkatesa Perumal College of Engineering & Technology, Puttur, Andhra pradesh, India².

ABSTRACT : For a power distribution system with distributed generation (DG) units, its fault current and induced overvoltage under abnormal conditions should be taken into account seriously. In consideration that applying superconducting fault current limiter (SFCL) may be a feasible solution, in this paper, the effects of a voltage compensation type active SFCL on them are studied through theoretical derivation and simulation. The active SFCL is composed of an air-core superconducting transformer and a PWM converter. The magnetic field in the air-core can be controlled by adjusting the converters output current, and then the active SFCLs equivalent impedance can be regulated for current limitation and possible overvoltage suppression. During the study process, in view of the changes in the locations of the DG units connected to the system, the DG units injection capacities and the fault positions, the active SFCLs current-limiting and overvoltage suppressing Characteristics are both simulated in MATLAB. The simulation results show that the active SFCL can play an obvious role in restraining the fault current and overvoltage, and it can contribute to avoiding damage on the relevant distribution equipment and improve the systems safety and reliability.

KEYWORDS: Distributed generation (DG), distribution system, overvoltage, short-circuit current, voltage compensation type active superconducting fault current limiter (SFCL).

I. INTRODUCTION

DUE to increased consumption demand and high cost of natural gas and oil, distributed generation (DG), which generates electricity from many small energy sources, is becoming one of main components in distribution systems to feed electrical loads. The introduction of DG into a distribution network may bring lots of advantages, such as emergency backup and peak shaving. However, the presence of these sources will lead the distribution network to lose its radial nature, and the fault current level will increase. Besides, when a single-phase grounded fault happens in a distribution system with isolated neutral, over voltages will be induced on the other two health phases, and in consideration of the installation of multiple DG units, the impacts of the induced over voltages on the distribution network's insulation stability and operation safety should be taken into account seriously.

Aiming at the mentioned technical problems, applying superconducting fault current limiter (SFCL) may be a feasible solution. For the application of some type of SFCL into a distribution network with DG units, a few works have been carried out, and their research scopes mainly focus on current-limitation and improvement of protection coordination of protective devices. Nevertheless, with regard to using a SFCL for suppressing the induced overvoltage, the study about it is relatively less. In view of that the introduction of a SFCL can impact the coefficient of grounding, which is a significant contributor to control the induced overvoltage's amplitude; the change of the coefficient may bring positive effects on restraining overvoltage.

We have proposed voltage compensation type active SFCL and analyzed the active SFCL's control strategy and its influence on relay protection. In addition, a 800 V/30 A laboratory prototype was made, and its working performances were confirmed well. In this paper, taking the active SFCL as an evaluation object, its effects on the fault current and overvoltage in a distribution network with multiple DG units are studied. In view of the changes in the locations of the DG units connected into the distribution system, the DG units' injection capacities and the fault positions, the current limiting and overvoltage-suppressing characteristics of the active SFCL are investigated in detail.

II. THEORETICAL ANALYSIS

2.1. Structure and Principle of the Active SFCL

As shown in Fig. 1(a), it denotes the circuit structure of the single-phase voltage compensation type active SFCL, which is composed of an air-core superconducting transformer and a voltage-type PWM converter. L_{s1} , L_{s2} are the self-inductance of two superconducting windings, and M_s is the mutual inductance. Z_1 is the circuit impedance and Z_2 is the load impedance. L_d and C_d are used for filtering high order harmonics caused by the converter. Since the voltage-type converter's capability of controlling power exchange is implemented by regulating the voltage of AC side, the converter can be thought as a controlled voltage source U_p . By neglecting the losses of the transformer, the active SFCL's equivalent circuit is shown in Fig. 1(b).

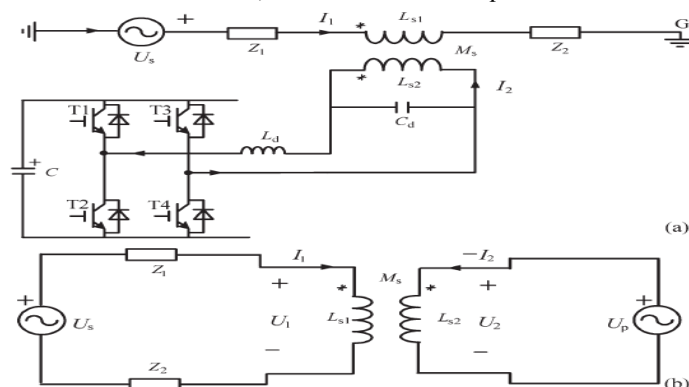

Fig. 1. Single-phase voltage compensation type active SFCL. (a) Circuit structure and (b) equivalent circuit.

In normal (no fault) state, the injected current (I_2) in the secondary winding of the transformer will be controlled to keep a certain value, where the magnetic field in the air-core can be compensated to zero, so the active SFCL will have no influence on the main circuit. When the fault is detected, the injected current will be timely adjusted in amplitude or phase angle, so as to control the superconducting transformer's primary voltage which is in series with the main circuit, and further the fault current can be suppressed to some extent. Below, the suggested SFCL's specific regulating mode is explained. In normal state, the two equations can be achieved:

$$\dot{U}_s = \dot{I}_1(Z_1 + Z_2) + j\omega L_{s1}\dot{I}_1 - j\omega M_s\dot{I}_2 \quad (1)$$

$$\dot{U}_p = j\omega M_s\dot{I}_1 - j\omega L_{s2}\dot{I}_2. \quad (2)$$

Controlling I_2 to make $j\omega L_{s1} I_1 - j\omega M_s I_2 = 0$ and the primary voltage U_1 will be regulated to zero. Thereby, the equivalent limiting impedance Z_{SFCL} is zero ($Z_{SFCL} = U_1/I_1$), and I_2 can be set as $I_2 = U_s / \sqrt{L_{s1}/L_{s2}/(Z_1 + Z_2)k}$, where k is the coupling coefficient and it can be shown as $k = M_s/\sqrt{L_{s1}L_{s2}}$. Under fault condition (Z_2 is shorted), the main current will rise from I_1 to I_{1f} and the primary voltage will increase to U_{1f} :

$$\dot{I}_{1f} = \frac{(\dot{U}_s + j\omega M_s\dot{I}_2)}{(Z_1 + j\omega L_{s1})} \quad (3)$$

$$\begin{aligned} \dot{U}_{1f} &= j\omega L_{s1}\dot{I}_{1f} - j\omega M_s\dot{I}_2 \\ &= \frac{\dot{U}_s(j\omega L_{s1}) - \dot{I}_2 Z_1(j\omega M_s)}{Z_1 + j\omega L_{s1}}. \end{aligned} \quad (4)$$

The current-limiting impedance Z_{SFCL} can be controlled in:

limiting

According to the difference in the regulating objectives of I_2 , there are three operation modes:

- 1) Making I_2 remain the original state, and the limiting impedance $Z_{SFCL-1} = Z_2(j\omega L_{s1})/(Z_1 + Z_2 + j\omega L_{s1})$.
- 2) Controlling I_2 to zero, and $Z_{SFCL-2} = j\omega L_{s1}$.
- 3) Regulating the phase angle of I_2 to make the angle difference between U_s and $j\omega M_s I_2$ be 180° . By setting $j\omega M_s I_2 = -c U_s$, and $Z_{SFCL-3} = cZ_1/(1 - c) + j\omega L_{s1}/(1 - c)$.

$$Z_{SFCL} = \frac{\dot{U}_{1f}}{\dot{I}_{1f}} = j\omega L_{s1} - \frac{j\omega M_s\dot{I}_2(Z_1 + j\omega L_{s1})}{\dot{U}_s + j\omega M_s\dot{I}_2}. \quad (5)$$

The air-core superconducting transformer has many merits, such as absence of iron losses and magnetic saturation, and it has more possibility of reduction in size, weight and harmonic than the conventional iron-core superconducting transformer. Compared to the iron-core, the air-core can be more suitable for functioning as a shunt reactor because of the large magnetizing current and it can also be applied in an inductive pulsed power supply to decrease energy loss for larger pulsed current and higher energy transfer efficiency. There is no existence of transformer saturation in the air-core, and using it can ensure the linearity of Z_{SFCL} well.

2.2. Applying the SFCL into a Distribution Network with DG

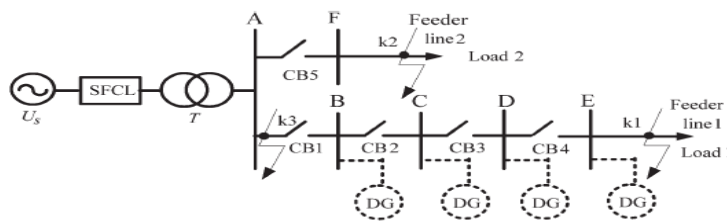

Fig. 2. Application of the active SFCL in a distribution system with DG units.

As shown in Fig. 2, it indicates the application of the active SFCL in a distribution network with multiple DG units, and the buses B-E are the DG units' probable installation locations. When a single-phase grounded fault occurs in the feeder line 1 (phase A, k_1 point), the SFCL's mode 1 can be automatically triggered, and the fault current's rising rate can be timely controlled. Along with the mode switching, its amplitude can be limited further. In consideration of the SFCL's effects on the induced overvoltage, the qualitative analysis is presented. In order to calculate the over voltages induced in the other two phases (phase B and phase C), the symmetrical component method and complex sequence networks can be used, and the coefficient of grounding G under this condition can be expressed as :

$$G = -1.5m / (2 + m) \pm j\sqrt{3}/2.$$

where $m = X_0/X_1$, and X_0 is the distribution network's zero-sequence reactance, X_1 is the positive-sequence reactance. Further, the amplitudes of the B-phase and C-phase over voltages can be described as:

$$U_{BO} = U_{CO} = \sqrt{3} \left| \frac{\sqrt{G^2 + G + 1}}{G + 2} \right| U_{AN} \quad (6)$$

where U_{AN} is the phase-to-ground voltage's root mean square (RMS) under normal condition.

As shown in Fig. 3, it signifies the relationship between the reactance ratio m and the B-phase overvoltage. It should be pointed out that, for the distribution system with isolated neutral-point, the reactance ratio m is usually larger than four. Compared with the condition without SFCL, the introduction of the active SFCL will increase the power distribution network's positive-sequence reactance under fault state. Since $X_0/(X_1 + Z_{SFCL}) < X_0/X_1$, installing the active SFCL can help to reduce the ratio m . And then, from the point of the view of applying this suggested device, it can lower the overvoltage's amplitude and improve the system's safety and reliability. Furthermore, taking into account the changes in the locations of the DG units connected into the distribution system, the DG units' injection capacities and the fault positions, the specific effects of the SFCL on the fault current and overvoltage may be different, and they are all imitated in the simulation analysis.

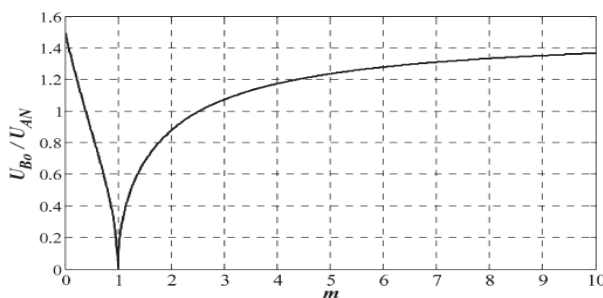

Fig. 3. Relationship between the reactance ratio m and the B-phase overvoltage.

III. SIMULATION STUDY

For purpose of quantitatively evaluating the current-limiting and overvoltage-suppressing characteristics of the active SFCL, the distribution system with DG units and the SFCL, as shown in Fig. 2 is created in MATLAB. The SFCL is installed in the behind of the power supply U_s , and two DG units are included in the system, and one of them is fixedly installed in the Bus B (named as DG_1). For the other DG, it can be installed in an arbitrary position among the Buses C–E (named as DG_2). The model's main parameters are shown in Table I. To reduce the converter's design capacity, making the SFCL switch to the mode 2 after the fault is detected, and the detection method is based on measuring the main current's different components by Fast Fourier Transform (FFT) and harmonic analysis.

3.1. Overvoltage-Suppressing Characteristics of the SFCL

Supposing that the injection capacity of each DG is about 80% of the load capacity (load 1), and the fault location is k_1 point (phase-A is shorted), and the fault time is $t = 0.2$ s, the simulation is done when the DG_2 is respectively installed in the Buses C, D, and E, and the three cases are:

Active SFCL	
Primary inductance	50 mH
Secondary inductance	30 mH
Mutual inductance	32.9 mH
Distribution Transformer	
Rated capacity	5000 kVA
Transformation ratio	35 kV/10.5 kV
Feeder Line	
Line length	$L_{AF} = 5$ km, $L_{AB} = 3$ km, $L_{BC} = 3$ km, $L_{CD} = 9$ km, $L_{DE} = 15$ km,
Line parameter	$(0.259 + j0.093) \Omega/\text{km}$
Power Load	
Load 1	50 Ω
Load 2	$(10 + j12) \Omega$

Fig. 4 shows the SFCL's overvoltage-suppressing characteristics and the waveforms with and without the SFCL are both listed. For the cases I, II, and III, the overvoltage's peak amplitude without SFCL will be respectively 1.14, 1.23, 1.29 times of normal value, and once the active SFCL is applied, the corresponding times will drop to 1.08, 1.17, and 1.2.

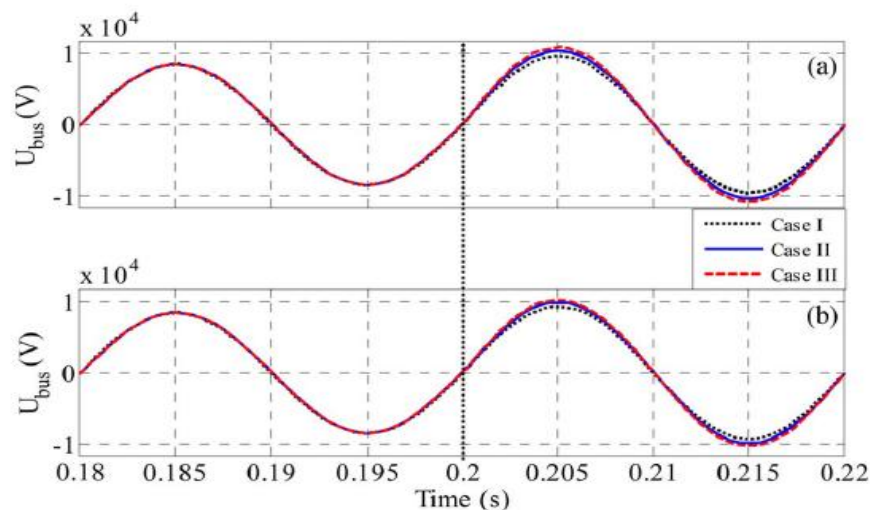

Fig. 4. Voltage characteristics of the Bus-A under different locations of DG units. (a) Without SFCL and (b) with the active SFCL.

During the study of the influence of the DG's injection capacity on the overvoltage's amplitude, it is assumed that the adjustable range of each DG unit's injection capacity is about 70% - 100% of the load capacity

(load 1), the two DG units are located in the Buses B and E, and the other fault conditions are unchanged, Table II shows the overvoltage's amplitude characteristics under this background. Along with the increase of the DG's injection capacity, the overvoltage will be accordingly rise, and once the injection capacity is equal or greater than 90% of the load capacity, the overvoltage will exceed acceptable limit (1.3 times). Nevertheless, if the active SFCL is put into use, the limit-exceeding problem can be solved effectively.

TABLE II
OVERVOLTAGE'S AMPLITUDE CHARACTERISTICS UNDER DIFFERENT INJECTION CAPACITIES OF DG UNITS

DG's injection capacity	Ratio of overvoltage to normal voltage	
	Without SFCL	With the active SFCL
70%	1.25	1.19
80%	1.29	1.2
90%	1.33	1.22
100%	1.38	1.29

3.2. Current-Limiting Characteristics of the SFCL

By observing the voltage compensation type active SFCL's installation location, it can be found out that this device's current-limiting function should mainly reflect in suppressing the line current through the distribution transformer. There upon, to estimate the most serious fault characteristics, the following conditions are designed: the injection capacity of each DG is about 100% of the load capacity (load 1), and the two DG units are separately installed in the Buses B and E. Moreover, the three-phase fault occurs at k_1 , k_2 , and k_3 points respectively, and the fault occurring time is $t = 0.2$ s. Here by, the line current characteristics are :

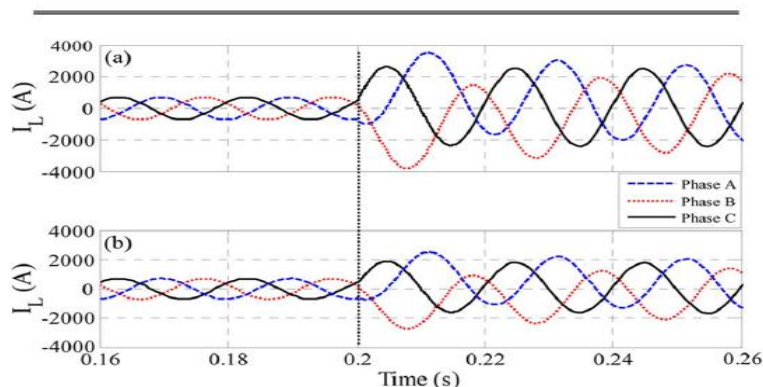

Fig. 5. Line current waveforms when the three-phase short-circuit occurs at k_3 point. (a) Without SFCL and (b) with the active SFCL.

As shown in Fig. 5, it indicates the line current waveforms with and without the active SFCL the three-phase short-circuit occurs at k_3 point. After installing the active SFCL, the first peak value of the fault currents (i_{Af} , i_{Bf} , i_{Cf}) can be limited to 2.51 kA, 2.69 kA, 1.88 kA, respectively, in contrast with 3.62 kA, 3.81 kA, 2.74 kA under the condition without SFCL. The reduction rate of the expected fault currents will be 30.7%, 29.4%, 31.4%, respectively.

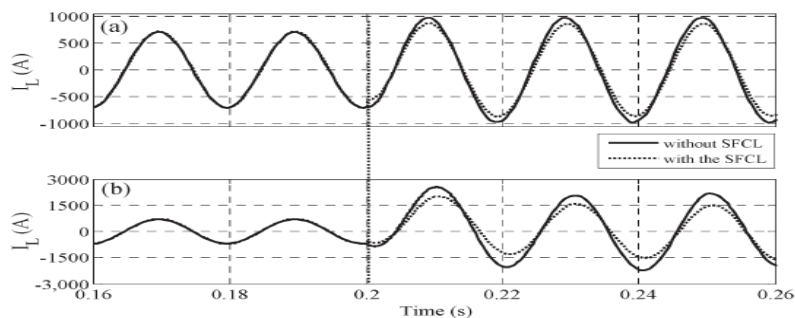

Fig. 6. Active SFCL's current-limiting performances under different fault locations. (a) k₁ point and (b) k₂ point.

Fig. 6 shows the SFCL's current-limiting performances when the fault location is respectively k₁ point and k₂ point (selecting the phase-A current for an evaluation). Along with the decrease of the distance between the fault location and the SFCL's installation position, the current-limiting ratio will increase from 12.7% (k₁ point) to 21.3% (k₂ point). Besides, as one component of fault current, natural response is an exponential decay DC wave, and its initial value has a direct relationship with fault angle. In other words, corresponding to different initial fault angles, the short-circuit current's peak amplitudes will be distinguishing.

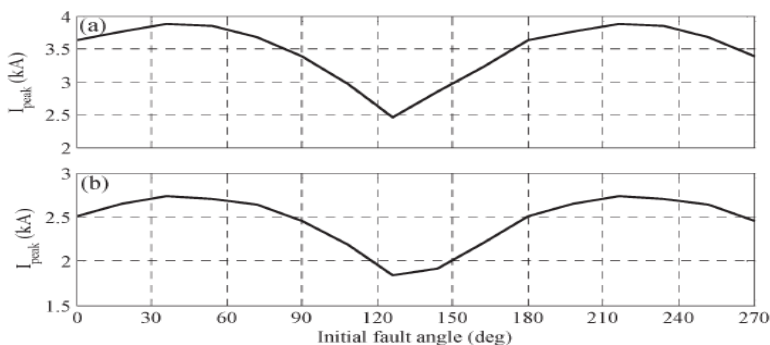

Fig. 7. Influence of initial fault angle on the peak amplitude of the A-phase short-circuit current. (a) Without SFCL and (b) with the active SFCL.

Through the application of the active SFCL, the influence of initial fault angle on the peak amplitude of the A-phase short-circuit current is analyzed in Fig. 7, where the fault location is k₃ point. It can be seen that, under the conditions with and without the SFCL, the short-circuit current's peak amplitude will be smallest when the fault angle is about 130°. At this fault angle, the power distribution system can immediately achieve the steady transition from normal state to fault state.

IV. CONCLUSION

In this paper, the application of the active SFCL into in a power distribution network with DG units is investigated. For the power frequency overvoltage caused by a single-phase grounded fault, the active SFCL can help to reduce the overvoltage's amplitude and avoid damaging the relevant distribution equipment. The active SFCL can as well suppress the short-circuit current induced by a three-phase grounded fault effectively, and the power system's safety and reliability can be improved. Moreover, along with the decrease of the distance between the fault location and the SFCL's installation position, the current-limiting performance will increase. In recently years, more and more dispersed energy sources, such as wind power and photovoltaic solar power, are installed into distribution systems. Therefore, the study of a coordinated control method for the renewable energy sources and the SFCL becomes very meaningful, and it will be performed in future.

REFERENCES

- [1]. S. Conti, "Analysis of distribution network protection issues in presence of dispersed generation," *Elect. Power Syst. Res.*, vol. 79, no. 1, pp. 49–56, Jan. 2009.
- [2]. A. S. Emhemed, R. M. Tumilty, N. K. Singh, G. M. Burt, and J. R. McDonald, "Analysis of transient stability enhancement of LVconnected induction microgenerators by using resistive-type fault current limiters," *IEEE Trans. Power Syst.*, vol. 25, no. 2, pp. 885–893, May 2010.
- [3]. S.-Y. Kim and J.-O. Kim, "Reliability evaluation of distribution network with DG considering the reliability of protective devices affected by SFCL," *IEEE Trans. Appl. Supercond.*, vol. 21, no. 5, pp. 3561–3569, Oct. 2011.
- [4]. S. A. A. Shahriari, A. Yazdian, and M. R. Haghifam, "Fault current limiter allocation and sizing in distribution system in presence of distributed generation," in *Proc. IEEE Power Energy Soc. Gen. Meet.*, Calgary, AB, Canada, Jul. 2009, pp. 1–6.
- [5]. S. Hemmati and J. Sadeh, "Applying superconductive fault current limiter to minimize the impacts of distributed generation on the distribution protection systems," in *Proc. Int. Conf. Environ. Electr. Eng.*, Venice, Italy, May 2012, pp. 808–813.
- [6]. S.-H. Lim, J.-S. Kim, M.-H. Kim, and J.-C. Kim, "Improvement of protection coordination of protective devices through application of a SFCL in a power distribution system with a dispersed generation," *IEEE Trans. Appl. Supercond.*, vol. 22, no. 3, p. 5601004, Jun. 2012.
- [7]. L. Chen, Y. Tang, J. Shi, and Z. Sun, "Simulations and experimental analyses of the active superconducting fault current limiter," *Phys. C*, vol. 459, no. 1/2, pp. 27–32, Aug. 2007.
- [8]. L. Chen, Y. Tang, J. Shi, Z. Li, L. Ren, and S. Cheng, "Control strategy for three-phase four wire PWM converter of integrated voltage compensation type active SFCL," *Phys. C*, vol. 470, no. 3, pp. 231–235, Feb. 2010.
- [9]. L. Chen, Y. J. Tang, J. Shi, L. Ren, M. Song, S. J. Cheng, Y. Hu, and X. S. Chen, "Effects of a voltage compensation type active superconducting fault current limiter on distance relay protection," *Phys. C*, vol. 470, no. 20, pp. 1662–1665, Nov. 2010.
- [10]. J. Wang, L. Zhou, J. Shi, and Y. Tang, "Experimental investigation of an active superconducting current controller," *IEEE Trans. Appl. Supercond.*, vol. 21, no. 3, pp. 1258–1262, Jun. 2011.

AUTHOR DETAILS:

1. V.N.Saraswathi-She has Completed M.Tech Degree with specialization Of PE&D in Sri Venkatesa Perumal College Of Engineering And Technology,Puttur Under JNTU Anantapur.She has Interested n power Converters, Electrical Circuits, Modern Power Electronics.

2. K.Kalpana-She has Completed M.Tech Degree with Specialization Of EPS in Sri Venkatesa Perumal College Of Engineering And Technology, Puttur Under JNTU Anantapur. She has Interested in Power Systems, Control Systems, Electrical circuits.