

Design & Analysis of ANFIS for Power quality enhancement Using Hybrid Filter Plug in Vehicle

K.DIVIJA¹, P.VINOD KUMAR²

¹(EEE, S.V.Engineering College for Women, India)

²(EEE, S.V.Engineering College for Women, India)

ABSTRACT: The main objective of this paper is the mitigation of current harmonics and the protection of point of common coupling from voltage distortions. Power quality issues related to plug in vehicles and focuses on improving electric vehicle load connection to the grid. While protecting the sensitive loads from voltage sags and swells riddled of the series transformer. A transformer less hybrid series active filter with ANFIS controller is proposed to enhance the power quality in single phase systems with critical loads. By controlling these control strategy which will present current harmonic distortion of nonlinear loads to flow in the utility side and corrects the power factor. ANFIS controller which will reduce the current harmonics and control implementation in simple, fast dynamic response and insensitive to load parameters. MATLAB/SIMULINK simulation results show the effectiveness of the proposed model.

KEYWORDS: Current harmonics, Power quality, Electric vehicle, Hybrid series active filter, ANFIS controller

I. INTRODUCTION

The estimation of future Smart Grids associated with electric vehicle charging stations has created a severe concern on all aspects of power quality of the power system, while widespread electric vehicle battery charging units [1],[2] have detrimental effects on harmonic voltage levels [3]. On the other hand, the development of harmonics fed from nonlinear loads like electric vehicle propulsion battery chargers [4],[5], which indeed have detrimental impacts on the power system and affect plant equipment, should be considered in the development of modern grids. The increased level of distortions in current which will increase the heating losses and cause the failure of electric equipment so the system efficiency will be reduced [6].

Now a days the usage of power electronic devices increases the current and voltage harmonics generated causing harmonic distortion which will decrease the power quality. Due to harmonic distortion so many problems are occur which are increased heat losses, life span reduction of transformer, operation problems on protecting relays, Circuit breakers and fuses. The solution of reducing the total harmonic distortion is by using filters are the best.

There are two types of active power devices which are shunt and series active filters including hybrid ones. In these the first category includes the series active filters including hybrid type. In these series active filters are used due to more advantages compared to shunt active filters. Series active filters (SeAFs) are less scattered than shunt type filters [7]. There are so many advantage compared to series type filters than shunt type. The second category of these filters is developed for the voltage issues on sensitive loads.

The hybrid series active filter are capable to mitigate current harmonics, thus ensures the power factor correction and eliminates the distortions of voltage at PCC [8].

The three-phase SeAFs are well research works are reported but single phase applications of SeAFs has limited research work in the literature. In this paper, a single-phase transformerless HSeAF is proposed and capable of cleaning up the grid-side connection bus bar from current harmonics generated by a nonlinear load [9].

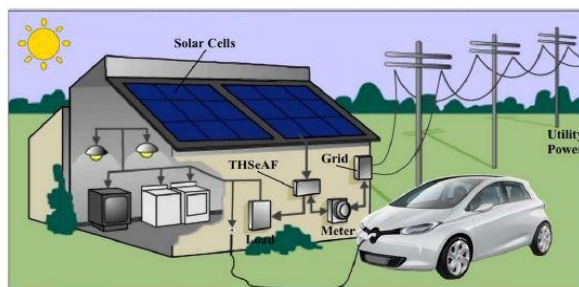

Fig1. Schematic Diagram of a compensator installation for single phase smart load

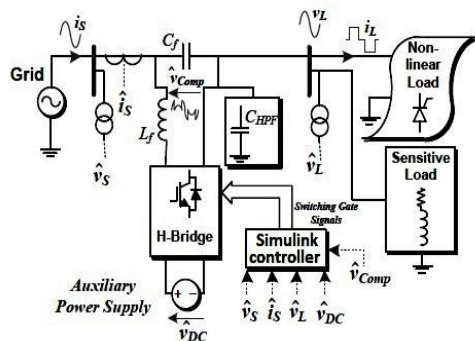

Fig 2.Schematic electric diagram of the single phase THSeAF

II. SYSTEM ARCHITECTURE

1) System configuration

The transformerless hybrid series active filter electrical diagram is shown in fig.2 which is composed of an H-bridge and passive filter.

H-bridge is the electronic circuit which enables a voltage to be applied across the load in any direction. H-bridge is connected in between the source and the load. A passive capacitor which ensures low impedance path for harmonics in current. A dc auxiliary source could be connected to inject power during voltage drop.

The system is implemented for a rated power of 2.2kVA. The system configuration parameters are shown in Table 1. A source voltage of 120Vrms is connected to a 1100 VA nonlinear load and a 998 VA linear load with a power factor of 0.46.

The THSeAF is connected in series to inject the compensation of voltage. On the dc side of the compensator the auxiliary dc-link energy storage system is installed. HSeAF are used to compensate distortions of the current type of nonlinear loads.

The THSeAF is avoided, the current harmonics flowed directly into the grid. As one can perceive, even during normal operation, the THD for current harmonics 4.4% distort the PCC, resulting in a voltage THD of 0.44%. The behavior of the system when the grid is highly polluted with 4.4% of THD is instanced.

The proposed configuration could be solely connected to the grid with no need of a bulky and costly series injection transformer, making this topology capable of compensating source current harmonics and voltage distortion at the PCC. Even if the number of switches has increased, the transformer less configuration is more cost-effective than any other series compensators, which generally uses a transformer to inject the compensation voltage to the power grid.

The optimized passive filter is composed of 5th, 7th, and high pass filters. In Table 2 the comparison between the different existing systems of configurations are shown.

TABLE I
 CONFIGURATION PARAMETERS

Definition	Symbolic representation	Value
Source voltage	V_s	120Vrms
Frequency	F	60Hz
Load resistance	$R_{\text{non-linear load}}$	11.5Ω
Load inductance	$L_{\text{non-linear load}}$	20mH
Load power	P_L	1kVA
Load power factor	PF	46%
Switching ripple filter inductance	L_f	5mH

Switching ripple filter capacitance	C_f	$2\mu\text{F}$
Sampling time	T_s	$40\mu\text{s}$
ANFIS controller loop frequency	F_{hys}	5kHz
Control gain for current harmonics	G	8Ω
Dc bus voltage of the THSeAF	$V_{\text{dc ref}}^*$	70v
Proportional gain	K_p	0.025
Integral gain	K_i	10

2) Operating principle

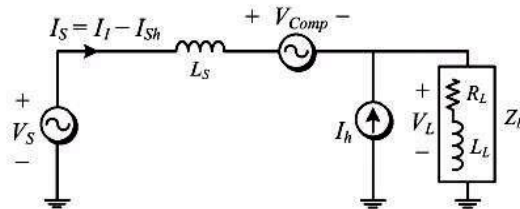

Fig 3...Equivalent circuit of THSeAF for current harmonics

TABLE 2
 COMPARISON OF THSEAF WITH PRIOR HSEAF

Definition	Proposed THSeAF	[8]	[11]	[12]
Injection transformer	Non	1	2	1
Semiconductor devices	4	4	8	4
No of Dc link storage elements	1+aux.pow	1+	1	2
Rating of AF to load power	10-30%	10-30%	10-30%	10-30%
Size and weight of the Transformer	Lowest	Good	High	Good
Power loss	Low	Low	Better	Low
Reliability	Good	Good	Low	Good
Current harmonic correction	Good	Low	Good	Good

Voltage harmonic correction	Good	Good	Better	Good
Power factor correction	Yes	No	Yes	Yes
Power injection to the grid	Yes	Yes	No	No

The SeAF represents a controlled voltage source (VSI). In order to prevent current harmonics i_{lh} to drift into the source, this series source should present low impedance for the fundamental component and high impedance for all harmonics as shown in fig.3.

The use of passive filter is to perform the compensation of current harmonics and to maintain the constant voltage free of distortions. The behavior of the SeAF for a current control approach is evaluated from the phasor's equivalent circuit shown in fig 3. The nonlinear load could be modeled by a resistance representing the active power consumed and a current source generating Current harmonics. Accordingly, the impedance Z_L represents the nonlinear load and the inductive load.

The SeAF operates as an ideal controlled voltage source (V_{comp}) having a gain (G) proportional to the current harmonics (I_{sh}) flowing to the grid(V_s)

$$V_{comp} = GI_{sh} - V_{Lh} \quad \dots(1)$$

This allows having individual equivalent circuit for the fundamental and harmonics

$$V_{source} = V_{s1} + V_{sh} \quad \dots(2)$$

$$V_L = V_{L1} + V_{Lh} \quad \dots(3)$$

The source current harmonics could be evaluated as

$$V_{sh} = -Z_s I_{sh} + V_{comp} + V_{Lh} \quad \dots(4)$$

$$V_{Lh} = Z_L (I_h - I_{sh}) \quad \dots(5)$$

Combining (4) and (5) leads to (6)

$$I_{sh} = \frac{V_{sh}}{(G - Z_s)} \quad \dots(6)$$

The source current will become clean of any harmonics ($I_{sh} \rightarrow 0$) occurs if the gain G is sufficiently large ($G \rightarrow \infty$). At grid side this will help to improve the voltage distortion.

In this THSeAF acts as a high impedance open circuit for current harmonics, while the shunt high pass filter tuned at the system frequency creates a low impedance path for all harmonics and open circuit for the fundamental. It also helps for PF correction.

III MODELLING AND CONTROL OF THE SINGLE –PHASE THSeAF

1) Average and small-signal modeling

Based on the average equivalent circuit of an inverter, the small-signal model of the proposed configuration can be obtained as in fig.4.

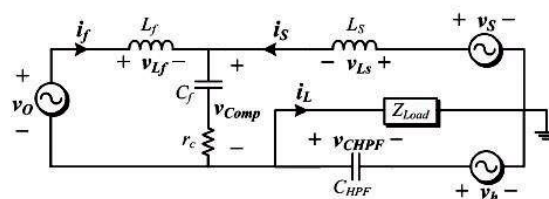

Fig.4. THSeAF small-signal model in series between grid and load

The mean converter output voltage and current are expressed as follows

$$\bar{V}_o = (2d-1)V_{DC} \quad \dots(7)$$

Where d= duty cycle of the upper switch during a switching period.

\bar{v} = average values in a switching period of voltage.

\bar{i} = average values in a switching period of current

(2d-1)=m then eq.(7) becomes

$$\begin{aligned} \bar{V}_o &= mV_{DC} \\ \bar{i}_{DC} &= m\bar{i}_f \end{aligned} \quad \dots\dots(8)$$

For fig 3.equivalent circuit calculating Thevenins voltage

$$\bar{V}_h(j\omega) = \frac{-j \bar{i}H}{CHPF} \quad \dots\dots(9)$$

The harmonics across the load will be zero when the harmonic frequency is high.The state space model for small signal model is

$$\dot{x} = Ax +Bu \quad \dots\dots(10)$$

Hence we obtain

$$\frac{d}{dt} \begin{bmatrix} \bar{v}cf \\ \bar{v}cHPF \\ \bar{i}_s \\ \bar{i}_f \\ \bar{i}L \end{bmatrix} = \begin{bmatrix} 0 & 0 & \frac{1}{Cf} & \frac{1}{Cf} & 0 \\ 0 & 0 & \frac{1}{CHPF} & 0 & \frac{-1}{CHPF} \\ \frac{-1}{Ls} & \frac{-1}{Ls} & \frac{-rc}{Ls} & \frac{-rc}{Ls} & 0 \\ \frac{-1}{Lf} & 0 & \frac{-rc}{Lf} & \frac{-rc}{Lf} & 0 \\ 0 & \frac{1}{Lf} & 0 & 0 & \frac{-RL}{LL} \end{bmatrix} \times \begin{bmatrix} \bar{v}cf \\ \bar{v}cHPF \\ \bar{i}_s \\ \bar{i}_f \\ \bar{i}L \end{bmatrix} + \begin{bmatrix} 0 & 0 & 0 \\ 0 & 0 & 0 \\ \frac{1}{Ls} & 0 & \frac{1}{Ls} \\ 0 & 0 & \frac{-1}{Ll} \end{bmatrix} \times \begin{bmatrix} \bar{v}_s \\ VDC \\ \bar{v}h \end{bmatrix} \quad \dots\dots (11)$$

The output vector is

$$Y = Cx +Du \quad \dots\dots (12)$$

Or

$$\begin{bmatrix} \bar{v}comp \\ \bar{v}l \end{bmatrix} = \begin{bmatrix} 1 & 0 & rc & rc & 0 \\ 0 & 1 & 0 & 0 & 0 \end{bmatrix} \times \begin{bmatrix} \bar{v}cf \\ \bar{v}cHPF \\ \bar{i}_s \\ \bar{i}_f \\ \bar{i}L \end{bmatrix} + \begin{bmatrix} 0 & 0 & 0 \\ 0 & 0 & -1 \end{bmatrix} \times \begin{bmatrix} \bar{v}_s \\ VDC \\ \bar{v}h \end{bmatrix} \quad \dots\dots(13)$$

By means of eq.(11) and (13),the state space representation of the model is obtained as shown in fig.4.To control the active part independently, the transfer function should be from the grid configuration. The T_{vm} transfer function explains the relation between the output voltages of the converter versus the duty cycle of the first leg converter's upper switch.

$$\begin{aligned} T_V(s) &= \frac{V_{comp}}{V_o} \\ &= \frac{rc Cf s+1}{LfCs^2+rc Cfs+1} \quad \dots\dots(14) \end{aligned}$$

$$\begin{aligned} T_{V_m}(s) &= \frac{V_{comp}}{m} \\ &= V_{DC} \cdot T_V(s) \quad \dots\dots(15) \end{aligned}$$

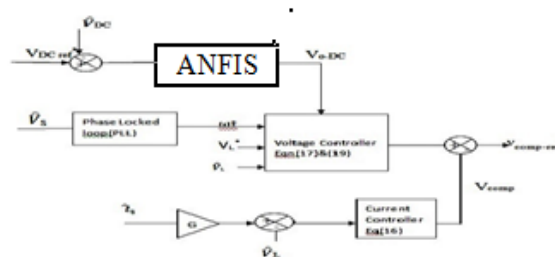

Fig.5.Active part control system scheme

To maintain an adequate supply on the load terminals a dc auxiliary source is used. It should absorb or inject power during voltage drop or swell to keep the voltage magnitude at the load terminals within a specified margin. A capacitor could be deployed, when the compensation of voltage sag and swells is less imperative. Consequently, the dc link voltage across the capacitor should be regulated as demonstrated in Fig.5.

2) Voltage and Current Harmonic Detection

The inner -loop control strategy is based on an indirect control principle. The controller for outer loop is used where a capacitor replaces the dc auxiliary source. A FFT was used to extract the phase degree and magnitude of the fundamental from current harmonics. To clean the grid from current harmonics fed from nonlinear load has the sufficient level of the control Gain G.

In this the second controller are used as proportional integrator (PI) controller. This controller used in outer loop was to raise the effectiveness of the controller when regulating the dc bus. Thus, more accurate and faster transient response was reached without compromising the compensation behavior of the system. According to this the gain G should be held in a suitable level, preventing the harmonics which flowing to the grid. The compensating voltage for current harmonic compensation is obtained from this equation

$$V_{\text{comp-i}}(t) = (-G\hat{I}_s + \hat{v}_L) - [-G\hat{I}_s 1Vl1] \cdot \sin(\omega_s t - \theta) \quad \dots\dots(16)$$

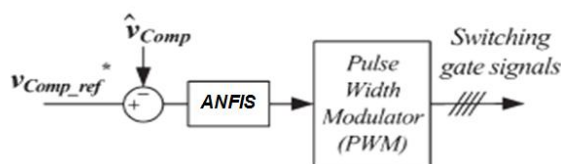

Fig.6. Block diagram of THSeAF and ANFIS controller

Here by, as voltage distortion at the load terminals is not craved, the voltage swell and sag would also be investigated in the inner loop. The closed loop eq (17) allows to indirectly maintain the voltage magnitude at the load side equal to V_L^* as a predefined value, within acceptable margins.

$$V_{\text{comp}} = \hat{v}_L - V_L^* \sin(\omega_s t) \quad \dots\dots(17)$$

The source current harmonics are obtained by extracting the fundamental component from the source current as

$$V_{\text{comp}}^* = V_{\text{comp-v}} - V_{\text{comp-i}} + V_{\text{DC-ref}} \quad \dots\dots(18)$$

Where the $V_{\text{DC-ref}}(t)$ is the required voltage to maintain the dc bus voltage.

$$V_{\text{DC-ref}}(t) = V_{\text{O-DC}} \cdot \sin(\omega_s t) \quad \dots\dots(19)$$

A phase locked loop was used to get the reference angular frequency (ω_s). The extracted harmonic current holds a fundamental component synchronized with the source voltage in order to correct the PF. This current represents the reactive power of the load. The gain G representing the resistance for harmonics converts current into a relative voltage.

3) Design of Adaptive Neuro-Fuzzy Controller

Adaptive neuro fuzzy inference system (ANFIS) integrates the best features of fuzzy systems and neural networks, and it has potential to capture the benefits of both in a single frame work. ANFIS is a kind of artificial neural network that is based on Takagi-sugeno fuzzy inference system, which is having one input an done output. Using a given data set, the toolbox function of ANFIS constructs a fuzzy inference system (FIS) where as the membership function parameters are tuned (adjusted) using a back propagation algorithm.

In order to have an idea of optimized ANFIS architecture for proposed control, an initial data is generated from normal PI regulator and the data is saved in workspace of MATLAB. Then the ANFIS command window is opened by typing anfis editor in the main MATLAB window. Then the data previously saved in workspace is loaded in the ANFIS command window to generate an optimized ANFIS architecture as shown in Fig.3..

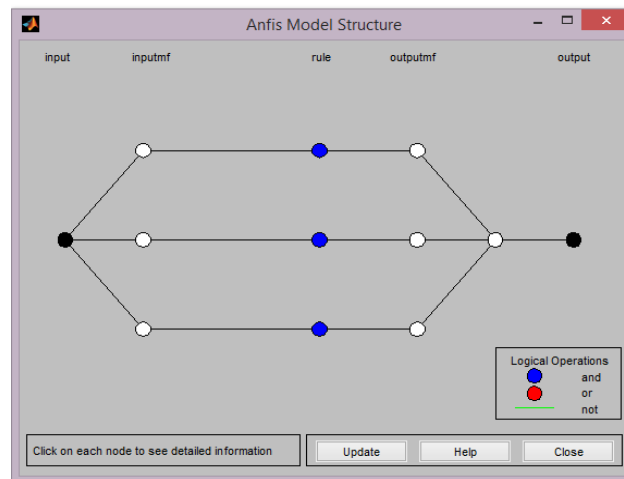

Figure.3 Optimized ANFIS architecture suggested by MATLAB/ANFIS editor

IV. SIMULATION RESULTS

The proposed THSeAF configuration was simulated in MATLAB/simulink using the discrete time of $T_s=10\mu s$. The combination of a single-phase nonlinear load and linear load with a rated power of 2kVA with a 0.74 lagging 120Vrms 60Hz variable source is used.

THSeAF connected in series to the system compensates the current harmonics and voltage distortions. A gain $G = 8\Omega (=1.9 \text{ p.u})$ was used to control current harmonics. During the grid's voltage distortion, the compensator regulates the load voltage magnitude, compensates the current harmonics and corrects the PF. The load voltage VL THD is 0.44%, while the source voltage is highly distorted ($THDV_s = 1.45\%$).

The grid is cleaned of current harmonics with a unity power factor (UPF) operation, and the THD is reduced to less than 1% in normal operation and less than 4% during grid perturbation. While the series controlled source cleans the current of harmonic components, the source current is forced to be in phase with the source voltage. The series compensator has the ability to slide the load voltage in order for the PF to reach unity. Furthermore, the series compensator could control the power flow between two PCCs.

The compensator shows high efficiency in normal operation where the total compensator losses including switching, inductor resistances, and damping resistances are equal to 44 W which is less than 2.5% of the system rated power. While cleaning the source current from harmonics and correcting the PF, the compensator regulates the load terminal voltage

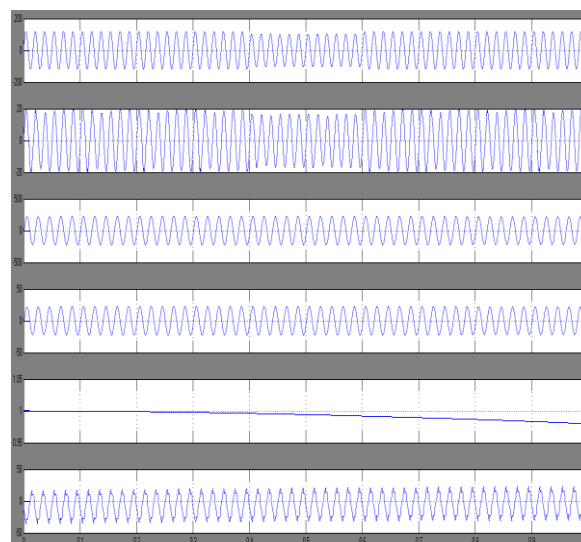

Fig.7. Simulation waveforms for voltage sag. (a). Source Voltage V_s , (b). Source current i_s , (c). load voltage V_L , (d) load current i_L , (e) Active-filter voltage V_{comp} , and (f) Harmonic current of the passive filter i_{PF} .

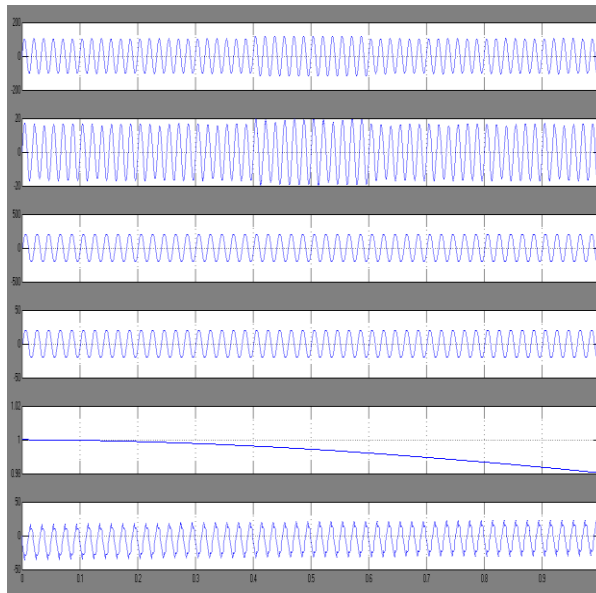

Fig.8.Simulation waveforms for voltage swell.(a).Source Voltage V_s ,(b).Source current i_s , (c).load voltage V_L , (d) load current i_L ,(e) Active-filter voltage V_{comp} , and (f) Harmonic current of the passive filter i_{PF} .

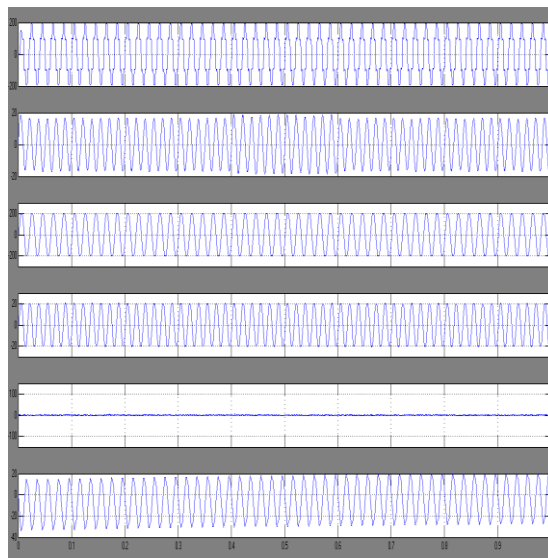

Fig.9.Simulation waveforms for voltage swell.(a).Source Voltage V_s ,(b).Source current i_s , (c).load voltage V_L , (d) load current i_L ,(e) Active-filter voltage V_{comp} , and (f) Harmonic current of the passive filter i_{PF} .

THD for current

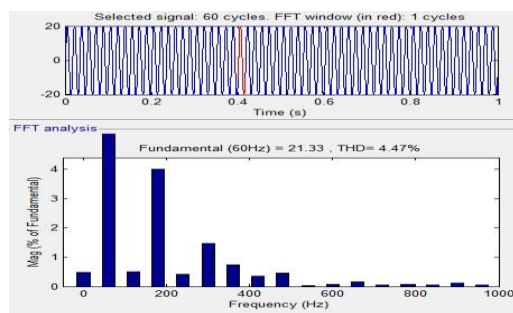

Fig10. Total harmonic distortion for current

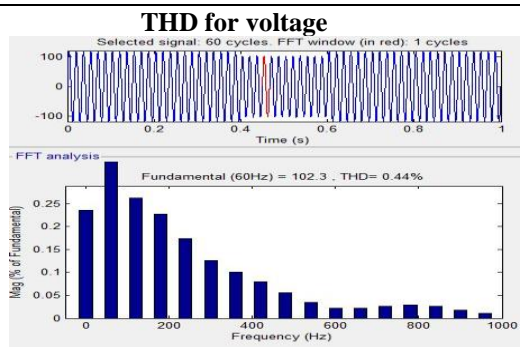

Fig11. Total harmonic distortion for voltage

In Fig.10 & 11 shows the total harmonic distortion levels in the current and voltage waveforms. The THD for current and voltage are 4.47% and 0.44%. The THSeAF reacts at once to this variation and does not interfere its operation functionality. To evaluate the compensator during utility perturbation, the power source becomes distorted. The source current become cleaned of the majority of harmonics are in the load current and has a unity power factor. The THSeAF defends the sensitive loads and maintain a sinusoidal and regulated voltage across the PCC of loads with a 0.44% of distortion. The compensator ought to inject power to maintain the load PCC voltage regulated at the desired level.

The harmonic content and THD factor of the source utility and load PCC shows improvement in THD, the load draws polluted current waveforms. Although the grid's voltage is polluted, the compensator in a hybrid approach regulates and maintains harmonic-free load voltage. The various levels of THD for proposed system and existing system are shown in Table-3.

TABLE-3

	Load voltage V_L (v)	Load current I_L (A)	Grid voltage V_s (v)	Grid current I_L (A)
Proposed system	4.6%	6.9%	0.44%	4.47%
Existing system	6.6%	19.7%	25%	5.2%

V. CONCLUSION

A THSeAF for power quality improvement was arised in this paper and tested by simulation for a single phase system. The paper highlighted the concept that, with the ever increase of nonlinear loads and higher exigency of the consumer for a reliable supply, concrete actions should be taken into consideration for future smart grids in order to smoothly integrate electric car battery chargers to the grid. The key novelty of the proposed solution is that the proposed configuration could improve the power quality of the system in a more general way by compensating a wide range of harmonics current, even though it can be seen that the THSeAF regulates and improves the PCC voltage. It was demonstrated that this active compensator responds properly to source voltage variations by providing a constant and distortion-free supply at load terminals. Furthermore, it eliminates source harmonic currents and improves the power quality of the grid without the usual bulky and costly series transformer.

REFERENCES

- [1] L. Jun-Young and C. Hyung-Jun, "6.6-kW onboard charger design using DCM PFC converter with harmonic modulation technique and two-staged dc/dc converter," *IEEE Trans. Ind. Electron.*, vol. 61, no. 3, pp. 1243–1252, Mar. 2014.
- [2] R. Seung-Hee, K. Dong-Hee, K. Min-Jung, K. Jong-Soo, and L. Byoung-Kuk, "Adjustable frequency duty-cycle hybrid control strategy for fullbridge series resonant converters in electric vehicle chargers," *IEEE Trans. Ind. Electron.*, vol. 61, no. 10, pp. 5354–5362, Oct. 2014
- [3] P. T. Staats, W. M. Grady, A. Arapostathis, and R. S. Thallam, "A statistical analysis of the effect of electric vehicle battery charging on distribution system harmonic voltages," *IEEE Trans. Power Del.*, vol. 13, no. 2, pp. 640–646, Apr. 1998.

- [4] A. Kuperman, U. Levy, J. Goren, A. Zafransky, and A. Savernin, "Battery charger for electric vehicle traction battery switch station," *IEEE Trans. Ind. Electron.*, vol. 60, no. 12, pp. 5391–5399, Dec. 2013.
- [5] Z. Amjadi and S. S. Williamson, "Modeling, simulation, control of an advanced Luo converter for plug-in hybrid electric vehicle energy-storage system," *IEEE Trans. Veh. Technol.*, vol. 60, no. 1, pp. 64–75, Jan. 2011.
- [6] H. Akagi and K. Isozaki, "A hybrid active filter for a three-phase 12-pulse diode rectifier used as the front end of a medium-voltage motor drive," *IEEE Trans. Power Del.*, vol. 27, no. 1, pp. 69–77, Jan. 2012.
- [7] D. Sixing, L. Jinjun, and L. Jiliang, "Hybrid cascaded H-bridge converter for harmonic current compensation," *IEEE Trans. Power Electron.*, vol. 28, no. 5, pp. 2170–2179, May 2013.
- [8] O. S. Senturk and A. M. Hava, "Performance enhancement of the single phase series active filter by employing the load voltage waveform reconstruction and line current sampling delay reduction methods," *IEEE Trans. Power Electron.*, vol. 26, no. 8, pp. 2210–2220, Aug. 2011
- [9] S. Rahmani, K. Al-Haddad, and H. Kanaan, "A comparative study of shunt hybrid and shunt active power filters for single-phase applications: Simulation and experimental validation," *Math. Comput. Simul.*, vol. 71, no. 4–6, pp. 345–359, Jun. 19, 2006.
- [10] H. Fujita and H. Akagi, "A practical approach to harmonic compensation in power systems-series connection of passive and active filters," *IEEE Trans. Ind. Appl.*, vol. 27, no. 6, pp. 1020–1025, Nov./Dec. 1991.
- [11] A. Varschavsky, J. Dixon, M. Rotella, and L. Mora, "Cascaded nine-level inverter for hybrid-series active power filter, using industrial controller," *IEEE Trans. Ind. Electron.*, vol. 57, no. 8, pp. 2761–2767, Aug. 2010.
- [12] X. P. n. Salmero and S. P. n. Litra, "A control strategy for hybrid power filter to compensate four-wires three-phase systems," *IEEE Trans. Power Electron.*, vol. 25, no. 7, pp. 1923–1931, Jul. 2010.