

OPTIMIZATION FOR OPTIMAL PLACEMENT OF FACTS IN VOLTAGE STABILITY ENHANCEMENT

M.H.DIVYA¹, K.VIJAYA BHASKAR², T.VARA PRASAD³

¹PG student, Department of Electrical & Electronics Engineering,
S.V.P.C.E.T, PUTTUR

²Associate professor, Department of Electrical & Electronics Engineering,
S.V.P.C.E.T, PUTTUR

³Associate professor, Department of Electrical & Electronics Engineering,
S.V.P.C.E.T, PUTTUR

Abstract: The present paper focuses mainly on two keys issues of power systems that is Minimization of real power loss and Maximization of voltage stability Limit (VSL).Optimal location and parameters of UPFC along with transformer taps are tuned with a view to simultaneously optimize the real power losses and voltage stability limit of interconnected transmission network. This issue is formulated as multi-objective, multivariable problem with an objective function incorporating both real power losses and voltage stability limit(VSL) and the UPFC location, its injected voltage and transformer tap positions are as the multi-variables. The Biologically inspired Evolutionary algorithm Known as Bacteria foraging algorithm is proposed in this paper for solving the multi-objective multivariable problem. The Proposed algorithm is tested on IEEE 39 bus power system for optimal location of UPFC and the results are presented.

KEYWORDS — Voltage stability, Bacteria foraging, continuation power flow (CPF), multi-objective, Multivariable, Optimal power flow (OPF), UPFC

I. INTRODUCTION

With the increased loading in existing power transmission systems due to increased demand the problem of voltage stability along with voltage collapse has become a major concern in power system operation, control and planning. Voltage collapse may be total or partial. As in the objective of an interconnected power system is to find the real and reactive power scheduling of each power plant in such way as to minimize the operating cost. It means that the generator's real and reactive power is allowed to vary within certain limits to meet a particular load demand with minimum fuel cost. This is known as optimal power flow (OPF) problem. Normally the Optimal Power Flow (OPF) is used to optimize the power flow solution of large scale power system. This is done by minimizing selected objective function while maintaining an acceptable system performance in terms of generator capability limits and the output of the compensating device. The objective function, which is named as cost function, may present economic costs, system security, or other objectives. The efficient reactive power planning enhances economic operation as well as system security.

The Optimal Power Flow (OPF) is solved by different methods which are successive linear programming (SLP),the Newton-based nonlinear programming method and with varieties of recently proposed interior point methods (IPM).With the use of Flexible AC transmission systems (FACTS) technology, there is a possibility of optimizing the power flow without resorting to generation rescheduling or topology changes has arisen. The Unified Power Flow controller which is the most advanced FACTS controller can provide significant flexibility in OPF by injecting a controlled series and shunt compensation.

Previously the research has been done on the deregulation which explains the proper coordination of the UPFC with the existing transformer taps already present in the system will not only improve the steady state operating limit of a power system but also observed that the system is more secure in terms of voltage collapse. There is a significant work on coordination of several FACTS controller by several authors to provide a secured transmission with minimized active power loss. It can be understood that in the continuation power flow (CPF) gives information regarding how much percentage overloading the system can stay continuously before a possible voltage collapse. In the authors have successfully incorporated the CPF problem into an OPF problem hence both the issues can be addressed simultaneously. In the present paper, the maximum percentage over loading (λ_{max}) the system can withstand is defined as voltage stability Limit (VSL) and incorporated along with the objective of real power loss minimization, making the problem multi-objective.

One of the main disadvantage, with the Classical Techniques is OPF solution lies in the fact that they are highly sensitive to starting points, due to a non monotonic solution surface. To eliminate such problems, evolutionary techniques have been applied in solving the OPF problem..

The paper employs a new algorithm from the family of evolutionary computation, known as Bacteria Foraging algorithm (BFA), to solve a combined CPF-OPF problem of real power loss minimization and VSL maximization of the system. The base of the algorithm is foraging behaviour of E-coli bacteria which is present in human intestine. The UPFC location its series injection voltage, and transformer tap positions are at a time optimized as control variables, so that the multiple objectives are fulfilled, considering all specified constraints. The obtained results so show its strength in solving highly nonlinear programming Problems. The main objectives of this paper are to optimize simultaneously the transformer taps, UPFC location, and its injection voltage for a the multiple objectives of loss minimization and VSL maximization

II. STATEMENT OF THE PROBLEM

Problem Formulation for Optimal Power Flow (OPF): The Optimal power flow (OPF) problem is a static constrained nonlinear optimization problem and it is formulated as

$$\text{Minimize } F(x, u) \quad (1)$$

$$\text{Subject to } g(x, u) = 0$$

$$h(x, u) \leq 0 \quad (2)$$

Where $F(x, u)$ is the objective function that is real power loss of the mesh connected with multi-machine test system. $g(x, u)$ is a set of nonlinear equality constraints to represent power flow, and $h(x, u)$ is a set of nonlinear inequality constraints (i.e., bus voltages, transformer/line MVA limits, etc.). Vector “ x ” consists of dependent variables, and u consists of control variables. In the problem mentioned above, the control variables are the transformer tap values, and both the magnitude and phase angle of UPFC series injected voltage (V_{se}).

III. MULTI-OBJECTIVE PROBLEM FORMULATION

The same objective of real power loss minimization is augmented with maximization of VSL. The VSL can be calculated through CPF, which introduces a load parameter defined as the percentage increase of generation and load from its base value. The resulting load and generation equation in terms of the load parameter is as follows

$$\begin{aligned} P_{Li} &= P_{Li0} (1 + \lambda) \\ Q_{Li} &= Q_{Li0} (1 + \lambda) \\ P_{Gi} &= P_{Gi0} (1 + \lambda) \end{aligned} \quad (3)$$

The load parameter can be increased until the system just reaches the verge of instability, which is also known as the “notch point” of the PV-curve. The maximum value of the load parameter (λ_{max}) is termed as VSL. The objective is to

$$\text{Optimize } F(x, u, \lambda_{max}) \quad (4)$$

$$\begin{aligned} \text{Subject to } \quad g(x, u) &= 0 \\ h(x, u) &\leq 0. \end{aligned} \quad (5)$$

The function to be optimized now can be represented as

$$F(x, u, \lambda_{max}) = G(x, u) + V(\lambda_{max}) \quad (6)$$

Where

$$\begin{aligned} G(x, u) &= \text{Real power loss} \\ V(\lambda_{max}) &= (1 / \lambda_{max}) \end{aligned} \quad (7)$$

The solution of CPF is carried out with the help of a suitably chosen continuation parameter. With the increase of “ λ ,” a new solution point is predicted first and then corrected in usual predictor and

corrector steps . Since the objective is to maximize the VSL, so its reciprocal is added to original cost function of real power loss so that the overall cost can be minimized.

IV. TERMINOLOGY OF BACTERIA FORAGING OPTIMIZATION

The idea of BFA is based on the fact that natural selection tends to eliminate animals with poor foraging strategies and favour those having successful foraging strategies. After many generations, poor foraging strategies are either eliminated or reshaped into good ones. The E. coli bacteria that are present in our intestines have a foraging strategy governed by four processes, namely, chemotaxis, swarming, reproduction, and elimination and dispersal .

Chemotaxis:

This process is achieved through swimming and tumbling. Depending upon the rotation of the flagella in each bacterium, it decides whether it should move in a predefined direction (swimming) or an altogether different direction (tumbling), in the entire lifetime of the bacterium. To represent a tumble, a unit length random direction, say, $\phi(j)$, is generated; this will be used to define the direction of movement after a tumble. In particular

$$\theta^i(j+1, k, l) = \theta^i(j, k, l) + C(i)\phi(j) \quad (8)$$

Where $\theta^i(j, k, l)$ represents the i th bacterium at j th the chemotactic, the k th reproductive, and the elimination and dispersal step. $C(i)$ is the size of the step taken in the random direction specified by the tumble. "C" is termed as the "run length unit."

Swarming:

It is always desired that the bacterium that has searched the optimum path of food should try to attract other bacteria so that they reach the desired place more rapidly. Swarming makes the bacteria congregate into groups and hence move as concentric patterns of groups with high bacterial density. Mathematically, swarming can be represented by

$$\begin{aligned} & j_{cc}(\theta, P(j, k, l)) \\ &= \sum_{i=1}^s j_{cc}^i(\theta, \theta^i(j, k, l)) \\ &= \sum_{i=1}^s \left[-d_{attract} \exp\left(-w_{attract} \sum_{m=1}^p (\theta_m - \theta_m^i)^2\right) \right] \\ &+ \sum_{i=1}^s \left[h_{repellent} \exp\left(-w_{repellent} \sum_{m=1}^p (\theta_m - \theta_m^i)^2\right) \right] \end{aligned} \quad (9)$$

Where $j_{cc}(\theta, P(j, k, l))$ is the cost function value to be added to the actual cost function to be minimized to present a time varying cost function. "S" is the total number of bacteria. "P" is the number of parameters to be optimized that are present in each bacterium. $d_{attract}$, $w_{attract}$, $h_{repellent}$, and $w_{repellent}$, are different coefficients that are to be chosen judiciously.

Reproduction:

The least healthy bacteria die, and the other healthiest bacteria each split into two bacteria, which are placed in the same location. This makes the population of bacteria constant

Elimination and Dispersal:

It is possible that in the local environment, the life of a population of bacteria changes either gradually by consumption of nutrients or suddenly due to some other influence. Events can kill or disperse all the bacteria in a region. They have the effect of possibly destroying the chemotactic progress, but in contrast, they also assist it, since dispersal may place bacteria near good food sources. Elimination and dispersal helps in reducing the behaviour of *stagnation* (i.e., being trapped in a premature solution point or local optima). The detailed mathematical derivations as well as theoretical aspect of this new concept are presented

Bacteria Foraging Optimization Algorithm:

The algorithm is discussed here in brief

Step 1: Initialization

The following variables are initialized.

- a) Number of bacteria (S) to be used in the search.
- b) Number of parameters (p) to be optimized.
- c) Swimming length N_s ,
- d) N_c The number of iterations in a chemotactic loop. ($N_c > N_s$)
- e) The number of reproduction.
- f) The number of elimination and dispersal events.
- g) The probability of elimination and dispersal.
- h) Location of each bacterium P (p, S, 1), i.e., random numbers on [0–1].
- i) The values of $d_{attract}$, $w_{attract}$, $h_{repellent}$, and $w_{repellent}$.

Step 2: Iterative algorithm for optimization:

This section models the bacteria population chemotaxis, swarming, reproduction, and elimination and dispersal

Initially ($j=k=l=0$) For the algorithm updating, θ^i automatically results in updating of “P.”

- a) Elimination-dispersal loop: $l = l + 1$
- b) Reproduction loop: $k = k + 1$
- c) Chemotaxis loop: $j = j + 1$

- a) For $i = 1, 2, \dots, S$, calculate cost function value for each bacterium i as follows.

- Compute value of cost $J_{sw}(i, j, k, l) = J(i, j, k, l) + J_{cc}(\theta^i(j, k, l), P(j, k, l))P(j, k, l)$ Is the location of bacterium corresponding to the global minimum cost function out of all the generations and chemotactic loops until that point (i.e., add on the cell-to-cell attractant effect for swarming behavior).

- Let $J_{last} = J_{sw}(i, j, k, l)$ to save this value since we may find a better cost via a run.
- End of for loop.

- b) For $i = 1, 2, \dots, S$, take the tumbling/swimming decision

- Tumble: Generate a random vector $\Delta(i) \in R^p$ with each element $\Delta_m(i) m = 1, 2, \dots, p$, a random number on [0, 1].
- Move: let

$$\theta^i(j+1, k, l) = \theta^i(j, k, l) + C(i) \frac{\Delta(i)}{\sqrt{\Delta^T(i)\Delta(i)}}$$

Fixed step size in the direction of tumble for bacterium is considered

- Compute $J(i, j+1, k, l)$ and then let $J_{sw}(i, j+1, k, l) = J(i, j+1, k, l) + J_{cc}(\theta^i(j+1, k, l), P(j+1, k, l))$

- Swim:

- 1) Let $m=0$; (counter for swim length)
- 2) While $m < N_s$ (have not climbed down too long)

- Let $m=m+1$

If $J_{sw}(i, j+1, k, l) < j_{last}$ (if doing better).let $J_{sw}(i, j+1, k, l)$ and Use this $\theta^i(j+1, k, k)$ to compute the new $J(i, j+1, k, l)$

- Else, let $m = N_s$. This is the end of the “While” statement.

- c) Go to next bacterium (i+1) if $i \neq S$ (i.e., go to “b”) to process the next bacterium.

- 4) If $j < N_c$, go to step 3. In this case, continue chemotaxis since the life of the bacteria is not over.

- 5) Reproduction:

- a) For the given k and l , and for each $i=1, 2 \dots S$, let $J_{health}^i = \min_{j \in \{1 \dots N_c\}} \{J_{sw}(i, j, k, l)\}$ be the

health of the bacterium i . Sort bacteria in order of ascending cost J_{health} (higher cost means lower health).

- b) The $S_r = S / 2$ bacteria with highest J_{health} values die and other S_r bacteria with the best value split (and the copies that are made are placed at the same location as their parent)
- 6) If $k < N_{re}$, go to 2; in this case, we have not reached the number of specified reproduction steps, so we start the next generation in the chemotactic loop.
- 7) Elimination-dispersal: For $i=1, 2, \dots, S$, with probability P_{ed} , eliminates and disperses each bacterium (this keeps the number of bacteria in the population constant). To do this, if one eliminates a bacterium, simply disperse it to a random location on the optimization domain. The parameter of the Bacteria foraging algorithm is shown in Table 1.

Table1: Control Parameter of the Bacteria Foraging Algorithm .

Sr. No	Parameter	Values
1	Number of Bactria	50
2	Maximum number of steps, N	4
3	Number of Chemotactic Steps, N_c	100
4	Number of Reproduction Steps N_{re}	4
5	Number of Elimination Dispersal steps N_{ed}	2
6	Probability, P_{ed}	0.25
7	Size of step, $C(i)$	0.1

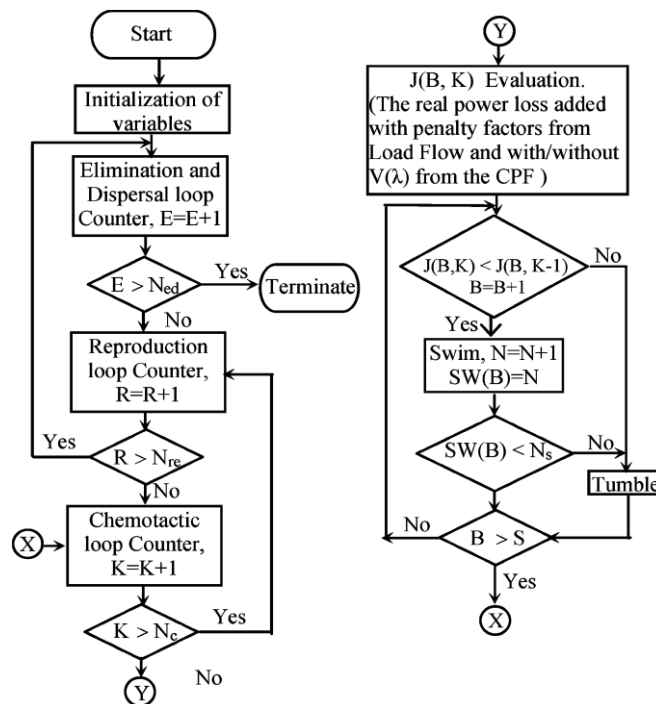

Fig.1. Flowchart of the bacteria foraging algorithm.

UPFC operation principal and its model:

The UPFC is one of the most versatile FACTS controller in the family of FACTS controllers proposed by Gyugyi for the regulation of voltage and power flow in a transmission line . It consists of two voltage source

converters (VSC) one shunt converter and other series converter as shown in figure2. The DC capacitors of the two converters are connected in parallel.

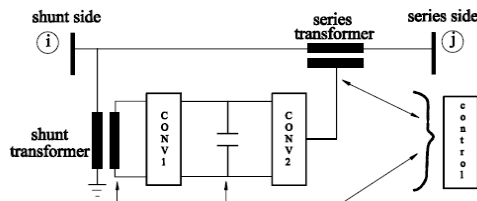

Fig2: The UPFC device circuit arrangement

In the UPFC device Shunt converter acts as STATCOM for controlling the reactive current and series converter acts as SSSC for injective the reactive voltage in the line. In the most advantage of the UPFC is, it simultaneously controls the real and reactive power of the line and voltage of the buses at which it is connected in the system.

In the present paper, One Unified Power flow Controller (UPFC) with injection model is connected at suitable location in the system. The UPFC injected model is shown is figure3

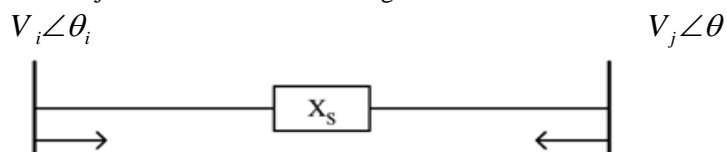

Fig3: UPFC injection model

$$P_{si} = rb_s V_i V_j \sin(\theta_{ij} + \gamma)$$

$$Q_{si} = rb_s V_i^2 \cos \gamma \tag{9}$$

$$P_{sj} = -rb_s V_i V_j \sin(\theta_{ij} + \gamma)$$

$$Q_{sj} = -rb_s V_i V_j \cos(\theta_{ij} + \lambda) \tag{10}$$

Test System: The 10- machine, 39-bus New England power system show in figure4 is considered for testing purpose and detail of the system data including 12 transformer nominal tap values are given .10-machine, 39 Bus New England power system line diagram is shown figure4

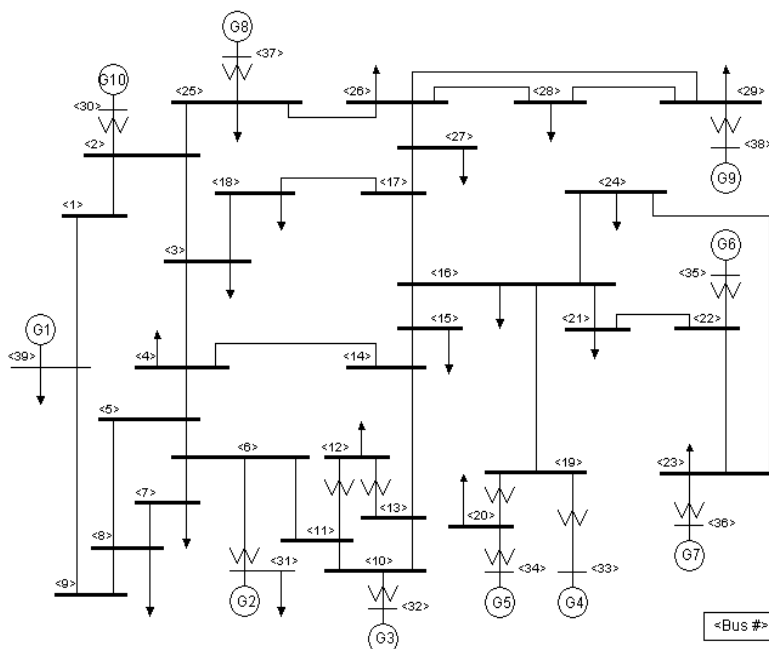

Fig4. New England power system layout

V. RESULTS&DISCUSSION

In the case of multi-objective optimization, the objective function can be formulated as

$$F = pf_1 + pf_2 + pf_3 + of + V(\lambda_{max}) \quad (11)$$

Where pf_1 , pf_2 , and pf_3 are the penalty factors added with the real power loss

of = Real power loss

$$pf_1 = 10 * abs(sign(V_{min} - 0.9) - 1) + 10 * abs(sign(V_{max} - 1.1) + 1)$$

$$pf_2 = 10 * abs(sign(trans_{max} - 15) + 1)$$

$$pf_3 = 10 * abs(sign(line_{max} - 20) + 1) \quad (12)$$

V_{max} and V_{min} refer the maximum and minimum limits of bus voltages for all the buses. Similarly, $trans_{max}$ and $line_{max}$ indicates the maximum MVA limits of the transformers and lines in the system. The values of $trans_{max}$ and $line_{max}$ are selected at the double the maximum nominal values of respective quantities. UPFC location and its variables along with the transformer taps are simultaneously optimized can even decreased the overall cost function.

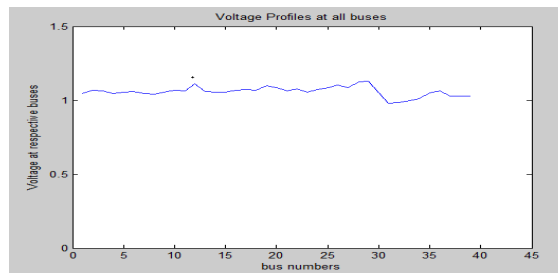

Fig5: Voltage profiles of all the buses at nominal load

With reference to fig.4, the total numbers of variables have become 15 that are 12 transformer tap positions, 3 UPFC variables. Base case the system has 0.43692 p.u. real power losses and It is clearly indicates that with BFAM the real power losses are reduced and further the voltage stability limit is increased. For all the optimized transformer taps and UPFC variables, the corresponding losses and the VSL values are shown in table2. Figure6 shows the P-V curve of the weakest bus for all the three optimization schemes. The magnitude of voltage (with simultaneous optimization), obtained with BFAM optimization is shown in figure5. It is observed that all the bus voltages remain within the limits, and the generator buses maintain their specified voltages when the optimized variables are used

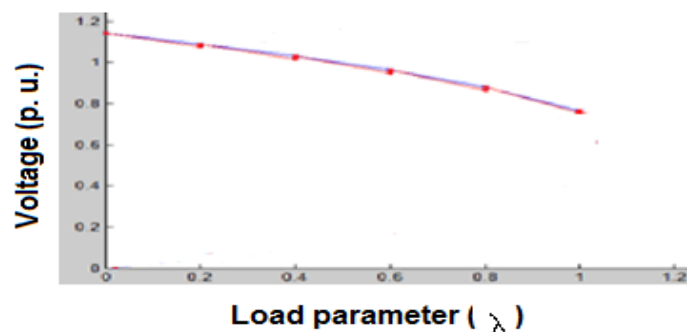

Fig6: PV curve of weakest bus (simultaneous UPFC and tap)

TABLE2: Simultaneous Optimized Values Of UPFC and Transformer Taps

Bacteria Forging Algorithm For Multi Objective Of Real Power Losses And Voltage Stability Limit					
S. No	Line No.	Transformer Taps	Injective Voltage	Real power losses	Voltage stability Limit
1	2-30	1.019	$ V_{se} = 0.0046000 p.u$ $\angle \delta_{se} = 3.140000 rad$ UPFC Location=2-3	0.346474	1.019987
2	10-32	1.070			
3	12-11	1.006			
4	12-13	1.072			
5	19-33	1.060			
6	19-20	1.009			
7	20-34	1.025			
8	22-35	1.000			
9	23-36	1.025			
10	25-37	1.070			
11	29-38	1.070			
12	6-31	1.070			

VI. CONCLUSION

In this paper a Biological inspired Bacteria Forging optimization is proposed to solve multi-objective, multi variable problem. The performance of the proposed algorithm for solving multi-objective that is real power loss minimization and Maximization of Voltage stability limit is demonstrated using IEEE-39 bus test system. The Test results shows that the evolutionary algorithm which is known as bacteria foraging, is used for Allocating transformer taps, and control of UPFC with a view to simultaneously minimize the real power loss and maximize the Voltage stability (VSL) of the system.. Finally from the simulation results it can be concluded that the, Bacteria foraging based optimization method is capable of achieving global optimal solution.

REFERENCES

- [1]. Hadi saadat power system analysis McGraw-Hill series in electrical and computer engineering Senior Consulting Editor, Stephen W. Director, University of Michigan, Ann Arbor
- [2]. P. Ristanovic, "Successive linear programming based OPF solution," Optimal Power Flow: Solution Techniques, Requirements and Challenges, IEEE Power Eng. Soc., pp. 1–9, 1996.
- [3]. D.I. Sun, B. Ashley, B. Brewer, B.A. Hughes, W.F. Tinney, Optimal power flow by Newton approach, IEEE Transactions on Power Apparatus and Systems 103 (1984) 2864–2875
- [4]. S. Granville, "Optimal power dispatch through interior point methods," IEEE Trans. Power Syst., vol. 9, no. 4, pp. 1780–1787, Nov. 1994.
- [5]. M. Noroozian, L. Angquist, M. Ghandhari, and G. Anderson, "Use of UPFC for optimal power flow control," IEEE Trans. Power Del., vol. 12, no. 4, pp. 1629–1634, Oct. 1997.
- [6]. G. Glanzmann and G. Andersson, "Coordinated control of FACTS devices based on optimal power flow," in Proc. 37th Annu. North Amer. Power Symp., Ames, IA, Oct. 23–25, 2005. V. Ajjarapu and C. Christy, "The continuation power flow: a tool for steady state voltage stability analysis," IEEE Trans. Power Syst., vol. 7, no. 1, pp. 416–423, Feb. 1992.
- [7]. F. Milano, C. A. Canizares, and A. J. Conejo, "Sensitivity-based security- constrained OPF market clearing model," IEEE Trans. Power Syst., vol. 20, no. 4, pp. 2051–2060, Nov. 2005.
- [8]. J. Yuryevich and K. P. Wong, "Evolutionary programming based optimal power flow algorithm," IEEE Trans. Power Syst., vol. 14, no. 4, pp. 1245–1250, Nov. 1999